

Gebrauchsanleitung PK-Nr. 2797
Instructions / Mode d'emploi / Gebruiksaanwijzing /
инструкция по использованию / 使用说明 / Használati utasítás

PAIDI Möbel GmbH
Hauptstraße 87
97840 Hafenlohr
Germany
info@paidi.de

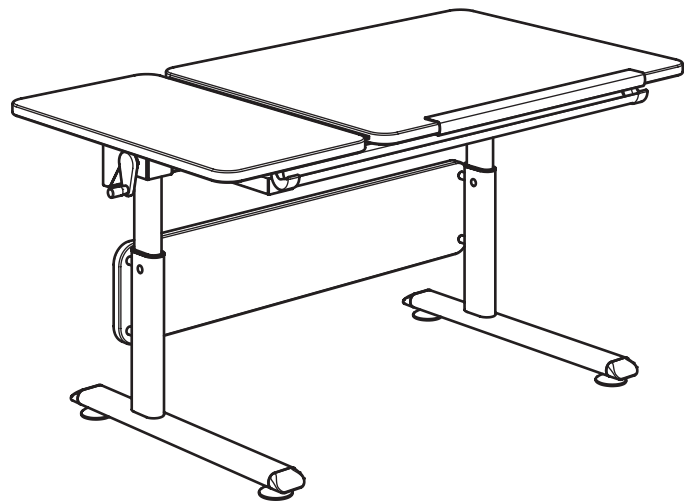
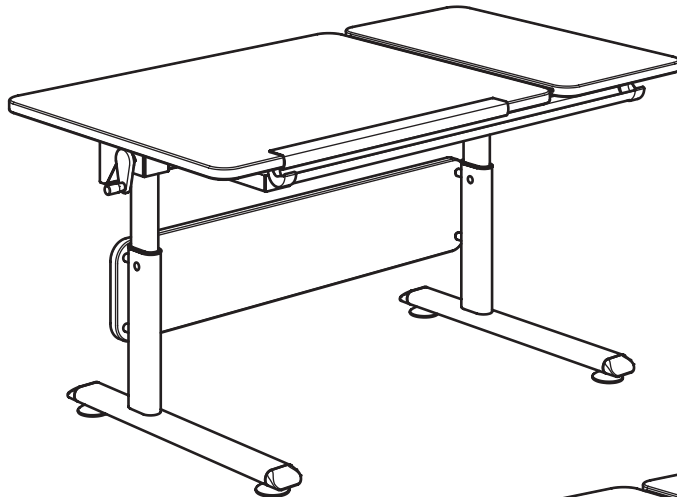

DIEGO
WEISS
Schreibtisch 130 GT

149 7831

149 7834

149 7838

149 7839

DIEGO
SILBER
Schreibtisch 130 GT

149 7731

149 7734

149 7738

149 7739

GINO
SILBER
Schreibtisch 130 GT

149 7934

149 7938

149 7939

DIEGO
Schwarz
Schreibtisch 130 GT

149 7631

149 7634

149 7638

149 7639



www.blauer-engel.de/uz38

- emissionsarm
- Holz aus nachhaltiger Forstwirtschaft





Warnhinweis!

Warning! / Avertissement! / Waarschuwing! / Предупреждение! / 警告! / Figyelmeztetés



PAIDI Möbel GmbH
Hauptstraße 87
97840 Hafenslohr
Germany
info@paidi.de

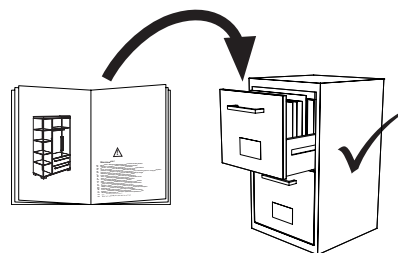

- DE Schraubenverbindungen von Zeit zu Zeit auf ihre Festigkeit prüfen, gegebenenfalls nachziehen, da die Stabilität der Konstruktion sonst nicht gegeben ist.**
- FR** Vérifier les connexions à vis de temps en temps, resserrer celles-ci le cas échéant, car, sinon, la stabilité de la construction ne serait pas assurée.
- GB** Check the tightness of the screw connections from time to time and tighten if necessary, as otherwise the stability of the construction is not assured.
- NL** Schroefverbindingen moeten van tijd tot tijd op hun stevigheid worden gecontroleerd en eventueel worden vastgedraaid, aangezien de stabiliteit van de constructie anders niet verzekerd is.
- ES** Compruebe de vez en cuando la firmeza de las uniones atornilladas y reapriete los tornillos si fuera necesario, pues de lo contrario quedaría afectada la estabilidad de la estructura.
- GR** Πού και πού ελέγχετε τη σταθερότητα των κοχλιωτών συνδέσεων κι εφ' όσον είναι ανάγκη, τις σφίγγετε ξανά, επειδή διαφορετικά δεν είναι η ευστάθεια της κατασκευής δεδομένη.
- IT** Controllare di tanto in tanto la tenuta delle connessioni a viti, all'occorrenza provvedere a serrarle di nuovo, poiché altrimenti non è garantita la stabilità della struttura.
- CZ** Čas od času zkontrolujte pevnost šroubových spojů, případně je dotáhněte, jinak nebude konstrukce stabilní.
- SL** Vijačne zveze od časa do časa preveriti glede na trdnost, po potrebi priviti, saj sicer stabilnost konstrukcije ne bo zagotovljena.
- PL** Połączenia śrubami sprawdzać od czasu do czasu pod kątem ich trwałości, ewentualnie dokręcać, gdyż inaczej konstrukcja nie jest stabilna.
- BG** Контролирайте от време на време дали болтовите съединения са добре завинтени, тъй като в противен случай не може да се гарантира стабилността на конструкцията.
- HR** S spojeve vijaka s vremena na vrijeme provjeriti u svezi čvrstoće, po potrebi stegnuti, jer inače nije zajamčena stabilnost konstrukcije.
- LT** Kartais patikrinkite varžtų jungčių stiprumą, prireikus suveržkite juos stipriau, nes priešingu atveju konstrukcija nebus stabili.
- RU** Перепроверяйте время от времени болтовые соединения. Они должны быть плотно затянуты. Это гарантирует стабильность конструкции.
- CN** 请经常的检查连接处的螺丝，如有发现松动请及时锁紧，否则将无法保障其稳定性。
- HU** Időről ellenőrizze a csavarokötések szorosságát, adott esetben a csavarokat után kell húzni, ellenkező esetben a szerkezet stabilitása nem adott.
- DE Pflegehinweis: Zum Reinigen der Oberflächen ein leicht-feuchtes Tuch oder ein handelsübliches Möbelpflegemittel verwenden.**
- FR** Indication sur l'entretien: pour nettoyer les surfaces, utiliser un chiffon légèrement humide ou un nettoyant pour meubles en vente dans le commerce
- GB** Caring for the...: In order to clean the surfaces please use a slightly damp cloth or commercially available furniture care product.
- NL** Verzorgingsanwijzing: Voor het reinigen van de oppervlakken een licht vochtig doek of een gebruikelijk meubelschoonmaakmiddel gebruiken.
- ES** Recomendaciones de cuidado: Para limpiar las superficies del mueble debe usar un trapo humedecido o un producto de limpieza de muebles comercial.
- GR** Οδηγίες περιποίησης: Για το καθάρισμα των επιφανειών να χρησιμοποιείτε ένα ελαφρά νοτισμένο πανάκι ή λούστρο επίπλων.
- IT** Indicazione per pulizia e cura: Per la pulizia delle superfici utilizzate un panno leggermente umido o un normale prodotto per la cura dei mobili.
- CZ** Pokyny k čištění: Na čištění povrchu použijte pouze navlhčený kousek látky nebo běžný prostředek na ošetřování nábytku.
- SL** Navodilo za nego: Za čiščenje površin uporabljajte malo vlažno cunjo ali trgovsko običajno sredstvo za nego pohištva.
- PL** Wskazówka pielęgnacyjna: do czyszczenia powierzchni stosować lekko wilgotną ściereczkę lub zwykły środek do pielęgnacji mebli.
- BG** Указание за поддържане: Използвайте леко навлажнена кърпа или обикновен препарат за поддържане на мебели, за да почистите повърхностите.
- HR** Upute za njegu: Za čišćenje površina upotrijebiti jednu lako navlaženu krpu i trgovačko uobičajeno sredstvo za njegu namještaja.
- LT** Rekomendacija priežiūrai: Paviršius valykite drėgna pašluoste arba parduotuvėse įsigytomis baldų priežiūros priemonėmis.
- RU** Рекомендации по уходу: для очистки поверхностей используйте слегка влажную тряпку или обычное средство по уходу за мебелью.
- CN** 保养说明: 清洁表面只需用稍微潮湿的布或普通的家具清洁剂即可。
- HU** Ápolás: A felületek tisztításához enyhén nedves ruhát vagy a kereskedelemben kapható bútörápoló terméket használgjon.
- AR** إرشاد للعناية: يرجى من أجل تنظيف الأسطح استخدام منديل رطب بعض الشيء أو استخدام إحدى مواد تنظيف الأثاث المتوفرة في الأسواق التجارية.

Höhenverstellung



- DE** Wenn der Schreibtisch in der Höhe verstellt werden soll, muß die Schreibtischplatte schräg gestellt werden.
- FR** Placer le plateau du bureau en position oblique pour régler la hauteur du bureau.
- GB** If the height of the desk is to be adjusted, the desk top must be tilted.
- NL** Indien het bureau in de hoogte moet worden versteld, moet het bureaublad schuin worden geplaatst.
- RU** Для изменения высоты стола столешницу необходимо установить под углом.
- CN** 如果要调整办公桌的高度，办公桌的桌板顶必须倾斜一个角度。
- HU** Ha az íróasztal magasságát állítani kell, akkor az asztallapot meg kell dönteni.

Höheneinstellung Empfehlungswerte

Recommended values for height adjustment / Réglage de la hauteur Valeurs recommandées / Hoogte-instelling advieswaarden / Рекомендуемые значения настроек высоты / 高度调整建议值 / A magasság beállítása - Ajánlott értékek

PAIDI Möbel GmbH
Hauptstraße 87
97840 Hafenlohr
Germany
info@paidi.de



		
< 142 cm	53 – 58 cm	30 – 34 cm
143 – 157 cm	59 – 64 cm	35 – 38 cm
158 – 172 cm	65 – 70 cm	39 – 44 cm
> 172 cm	71 – 79 cm	> 45 cm

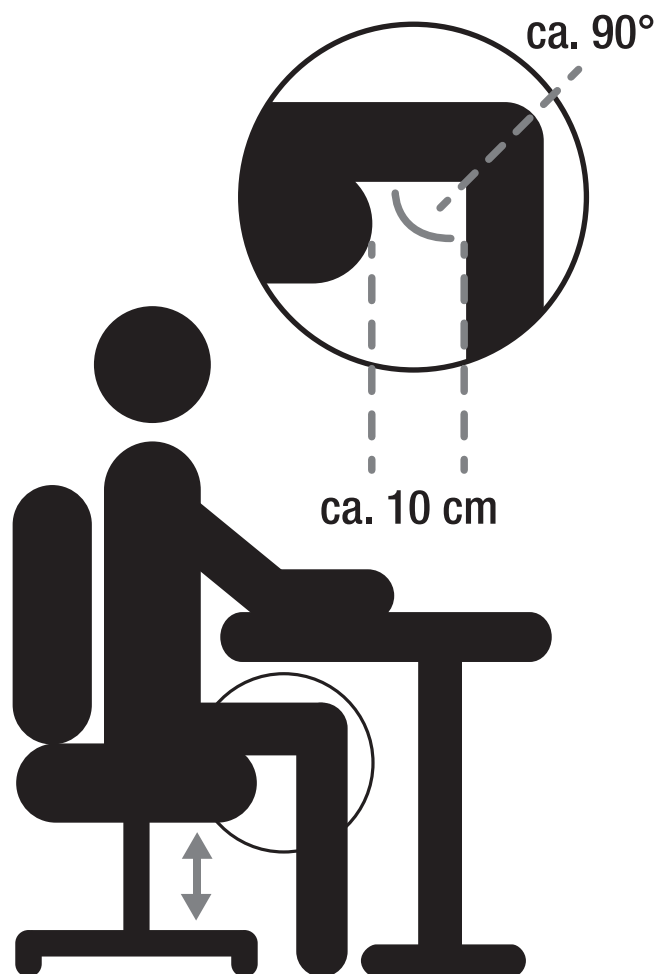

Beschläge

Fittings / Raccords / Hulpstukken /
Фурнитура / 配件 / Vasalatok

PAIDI Möbel GmbH
Hauptstraße 87
97840 Hafenlohr
Germany
info@paidi.de



1:1
DIN A4

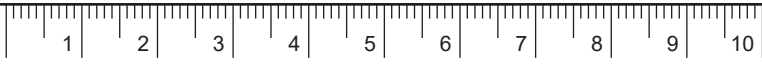

ca. 2,0h

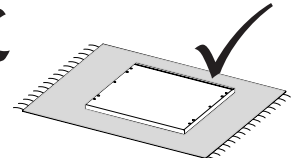
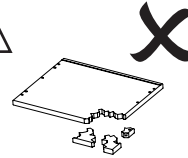
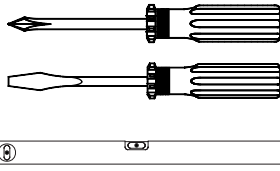
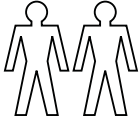

A 4x 671 7913 GRAU	B 2x 681 5550	C M5 x 30 1x 681 3819	D 6,3 x 15 8x 681 5060	E 2x 681 7475	F M4 x 10 6x 681 3804	H M6 x 80 3x 671 7756
-------------------------------------	--------------------------------	---	--	--------------------------------	---	---

J₁ GRAU 1x 671 7910	J₂ GRAU 1x 671 7911	K 3x 681 7047	L 4,0 x 35 3x 681 4909	M 4 x 35 4x 681 5001	N 4,0 x 20 4x 681 4917	O 26 mm 2x 671 7762	P 1x 681 7494	T M6 x 50 2x 681 3956
--	--	--------------------------------	--	--	--	---	--------------------------------	---

U M6 x 15 8x 670 0001	V M8 x 55 4x 670 0002	W 4x 670 0003	X M6 x 40 2x 671 7755	Y M6 x 30 4x 671 7914	 SW4 lang 1x 681 3010	 SW2,5 1x 671 3005	 SW5 1x 681 3014
---	---	--------------------------------	---	---	--------------------------------	-----------------------------	---------------------------

DIEGO
WEISS
Schreibtisch 130 GT

149 7831

149 7834

149 7838

149 7839

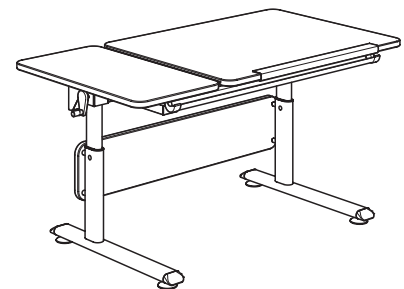
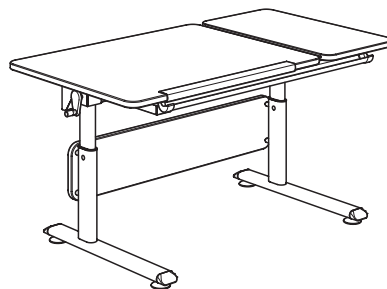

Code-Nr.: 681 1009

1x
15

1x
16

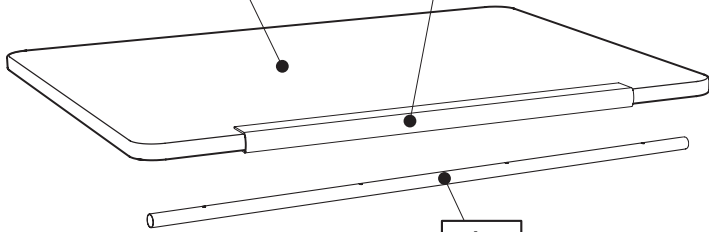

1x
14

Code-Nr.: 671 7909

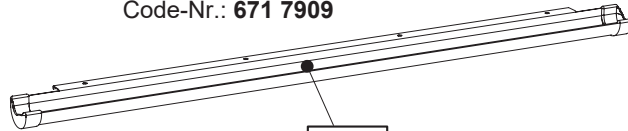

1x
13

Code-Nr.: 671 7908

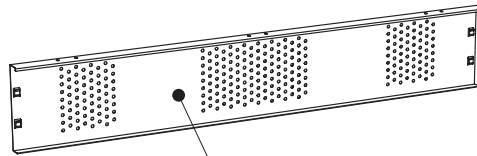

1x
10

Code-Nr.: 670 0081

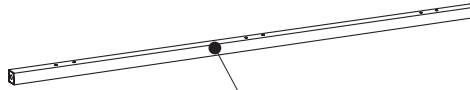

1x
9

Code-Nr.: 671 7906

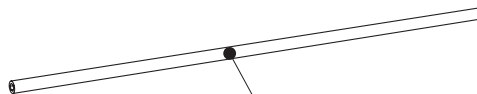

1x
7

Code-Nr.: 671 7903

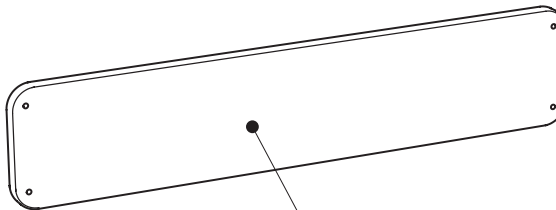

1x
8

Code-Nr.: 670 0051

2x
1

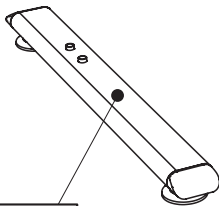

Code-Nr.: 670 0021

1x
2



Code-Nr.: 670 0011

1x
3

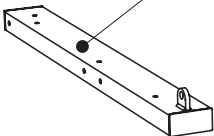

Code-Nr.: 681 8605

1x
6



Code-Nr.: 670 0061

1x
11



Code-Nr.: 670 0071

1x
12



Code-Nr.: 681 7493

2x
18

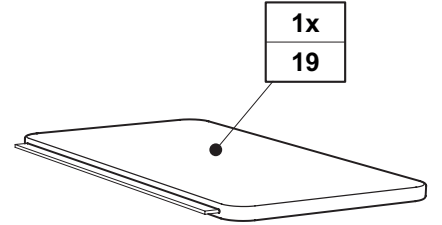
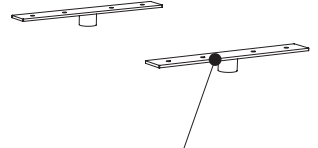

1x
19

Code-Nr.: 681 8604

1x
17



Code-Nr.: 670 0031

1x
5

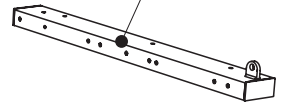

Code-Nr.: 670 0041

1x
4

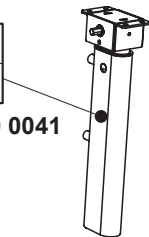

Beschläge

Fittings / Raccords / Hulpstukken /
Фурнитура / 配件 / Vasalatok

PAIDI Möbel GmbH
Hauptstraße 87
97840 Hafenlohr
Germany
info@paidi.de









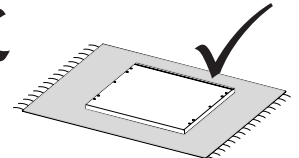
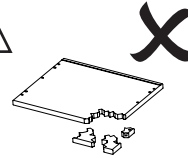
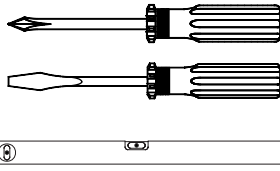
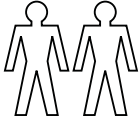

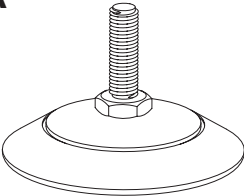
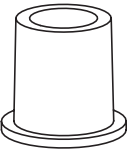



1:1
DIN A4



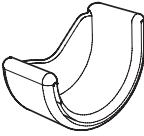
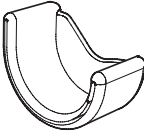



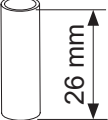

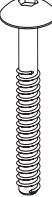
ca. 2,0h

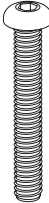

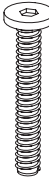
A  4x 671 7775 Schwarz	B  2x 681 5550	C  M5 x 30 1x 681 3819	D  6,3 x 15 8x 681 5060	E  2x 681 7475	F  M4 x 10 6x 681 3804	H  M6 x 80 3x 671 7756
---	---	--	---	---	--	--

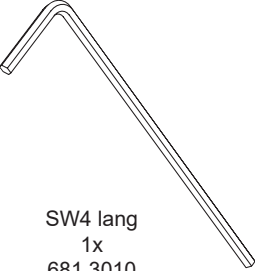
J₁  Schwarz 1x 671 7792	J₂  Schwarz 1x 671 7793	K  3x 681 7047	L  4,0 x 35 3x 681 4909	M  4 x 35 4x 681 5001	N  4,0 x 20 4x 681 4917	O  26 mm 2x 671 7762	P  1x 681 7494	T  M6 x 50 2x 681 3956
---	--	---	--	---	--	---	---	---

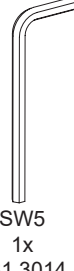
U  M6 x 15 8x 670 0001	V  M8 x 55 4x 670 0002	W  4x 670 0003	X  M6 x 40 2x 671 7755	Y  M6 x 30 4x 671 7914	 SW4 lang 1x 681 3010	 SW2,5 1x 671 3005	 SW5 1x 681 3014
--	--	---	--	--	---	---	--

DIEGO
SILBER

Schreibtisch 130 GT

149 7731
149 7734
149 7738
149 7739

GINO
SILBER

Schreibtisch 130 GT

149 7934
149 7938
149 7939

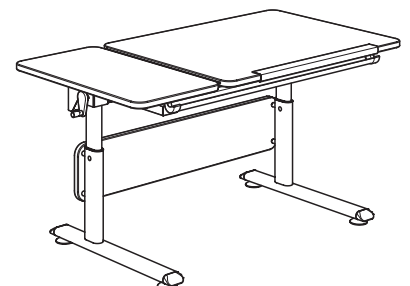
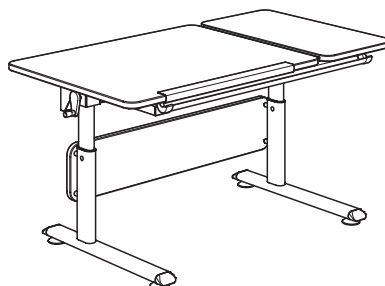

Code-Nr.: 681 1009

1x
15

1x
16

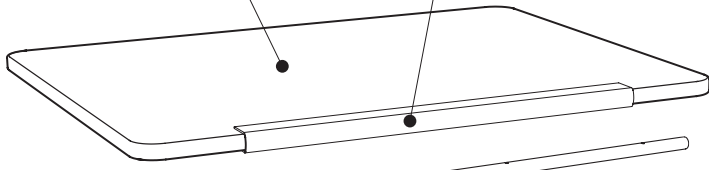

1x
14

Code-Nr.: 671 7497

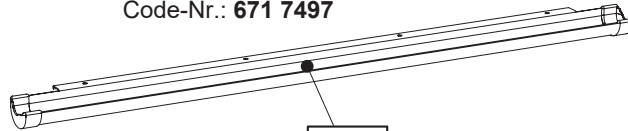

1x
19

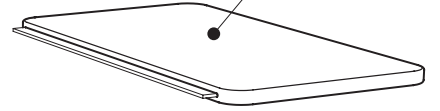

2x
18

Code-Nr.: 681 7493

Code-Nr.: 670 0079

1x
12



Code-Nr.: 671 7798

1x
17



Code-Nr.: 670 0069

1x
11



Code-Nr.: 671 7499

1x
6



Code-Nr.: 671 7796

1x
13

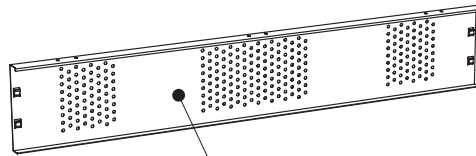

1x
10

Code-Nr.: 670 0089

Code-Nr.: 670 0039

1x
5

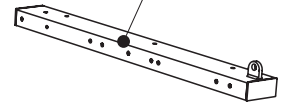

Code-Nr.: 670 0019

1x
3

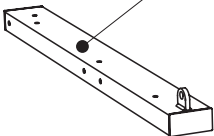

Code-Nr.: 671 7494

1x
9

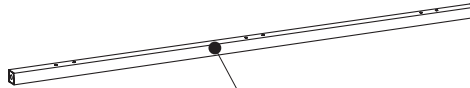

Code-Nr.: 670 0049

1x
4



Code-Nr.: 670 0029

1x
2



Code-Nr.: 671 7492

1x
7

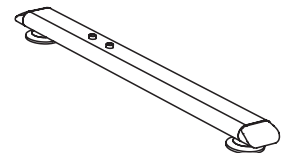
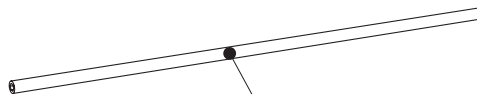

Code-Nr.: 670 0059

2x
1

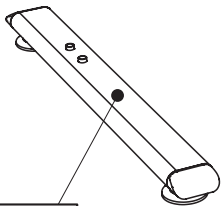

1x
8

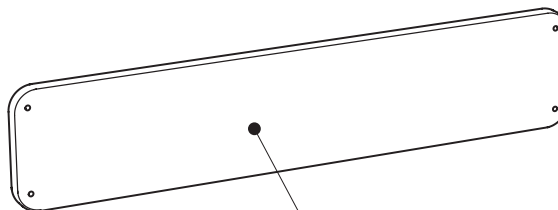

Beschläge

Fittings / Raccords / Hulpstukken /
Фурнитура / 配件 / Vasalatok

PAIDI Möbel GmbH
Hauptstraße 87
97840 Hafenlohr
Germany
info@paidi.de



1:1
DIN A4



ca. 2,0h

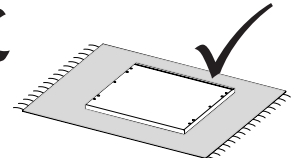
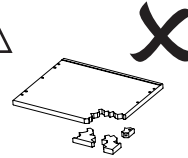
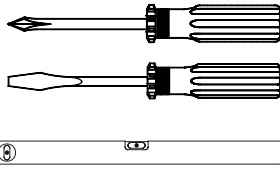
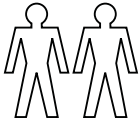

A 4x 671 7775 Schwarz	B 2x 681 5550	C M5 x 30 1x 681 3819	D 6,3 x 15 8x 681 5060	E 2x 681 7475	F M4 x 10 6x 681 3804	H M6 x 80 3x 671 7756
--	--------------------------------	---	--	--------------------------------	---	---

J₁ Schwarz 1x 671 7792	J₂ Schwarz 1x 671 7793	K 3x 681 7047	L 4,0 x 35 3x 681 4909	M 4 x 35 4x 681 5001	N 4,0 x 20 4x 681 4917	O 26 mm 2x 671 7762	P 1x 681 7494	T M6 x 50 2x 681 3956
---	---	--------------------------------	--	--	--	---	--------------------------------	---

U M6 x 15 8x 670 0001	V M8 x 55 4x 670 0002	W 4x 670 0003	X M6 x 40 2x 671 7755	Y M6 x 30 4x 671 7914	 SW4 lang 1x 681 3010	 SW2,5 1x 671 3005	 SW5 1x 681 3014
---	---	--------------------------------	---	---	--------------------------------	-----------------------------	---------------------------

DIEGO
Schwarz
Schreibtisch 130 GT

149 7631

149 7634

149 7638

149 7639

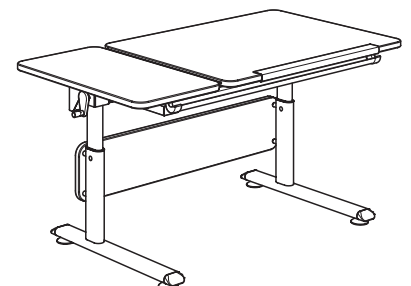
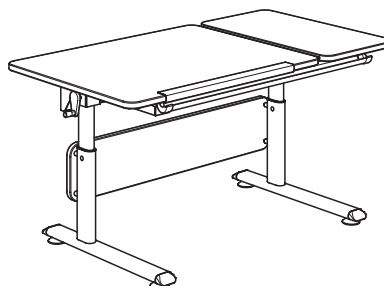

Code-Nr.: 681 1009

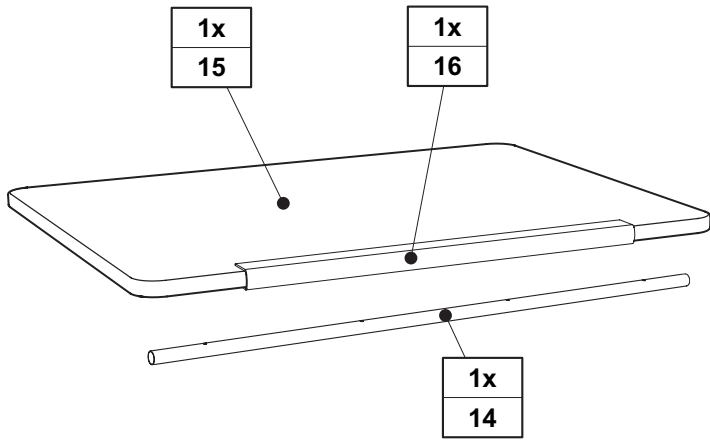

Code-Nr.: 671 7969

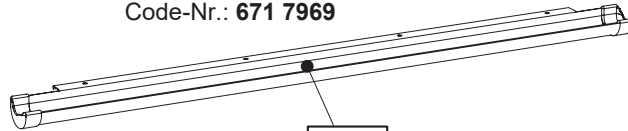

Code-Nr.: 671 7968

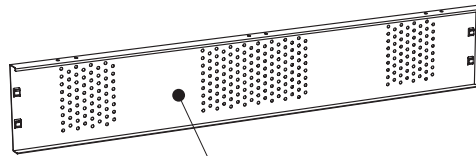

Code-Nr.: 670 0088

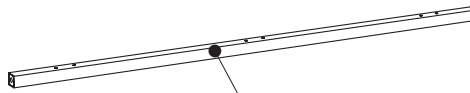

Code-Nr.: 671 7966

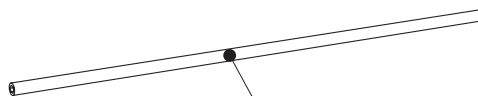

Code-Nr.: 671 7963

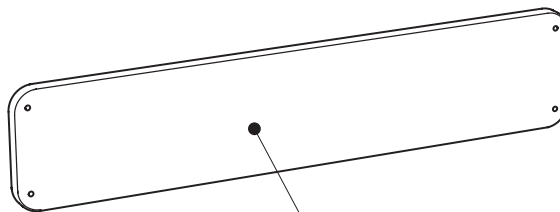

1x
19

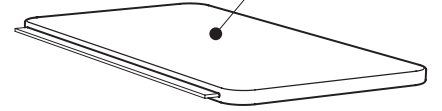

2x
18

Code-Nr.: 681 7493

Code-Nr.: 670 0078



Code-Nr.: 671 7972

1x
17



Code-Nr.: 670 0038

1x
5

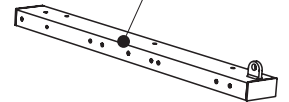

1x
4
Code-Nr.: 670 0048

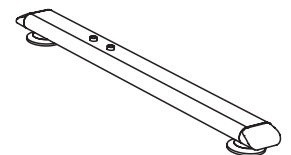
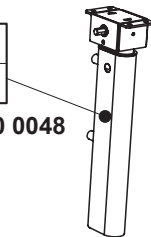

Code-Nr.: 670 0068

1x
11



Code-Nr.: 670 0018

1x
3

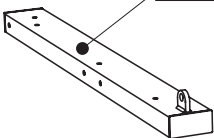

1x
2
Code-Nr.: 670 0028

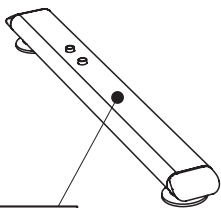

2x
1

Code-Nr.: 670 0058

V1

Vorbereitung / Preparation /
Préparation / Voorbereiding /
Подготовка / 准备 / Előkészítés

V1.1

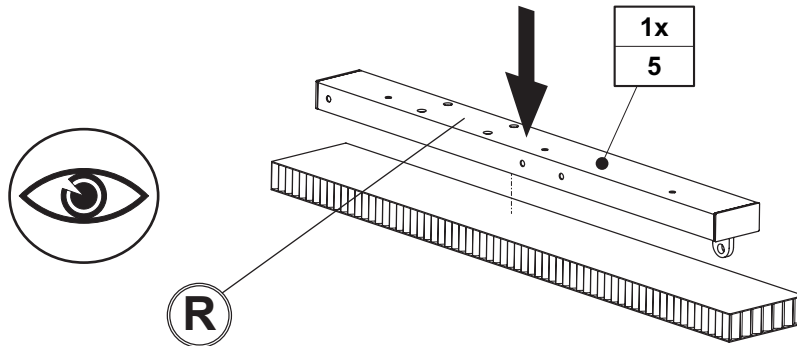

V1.2

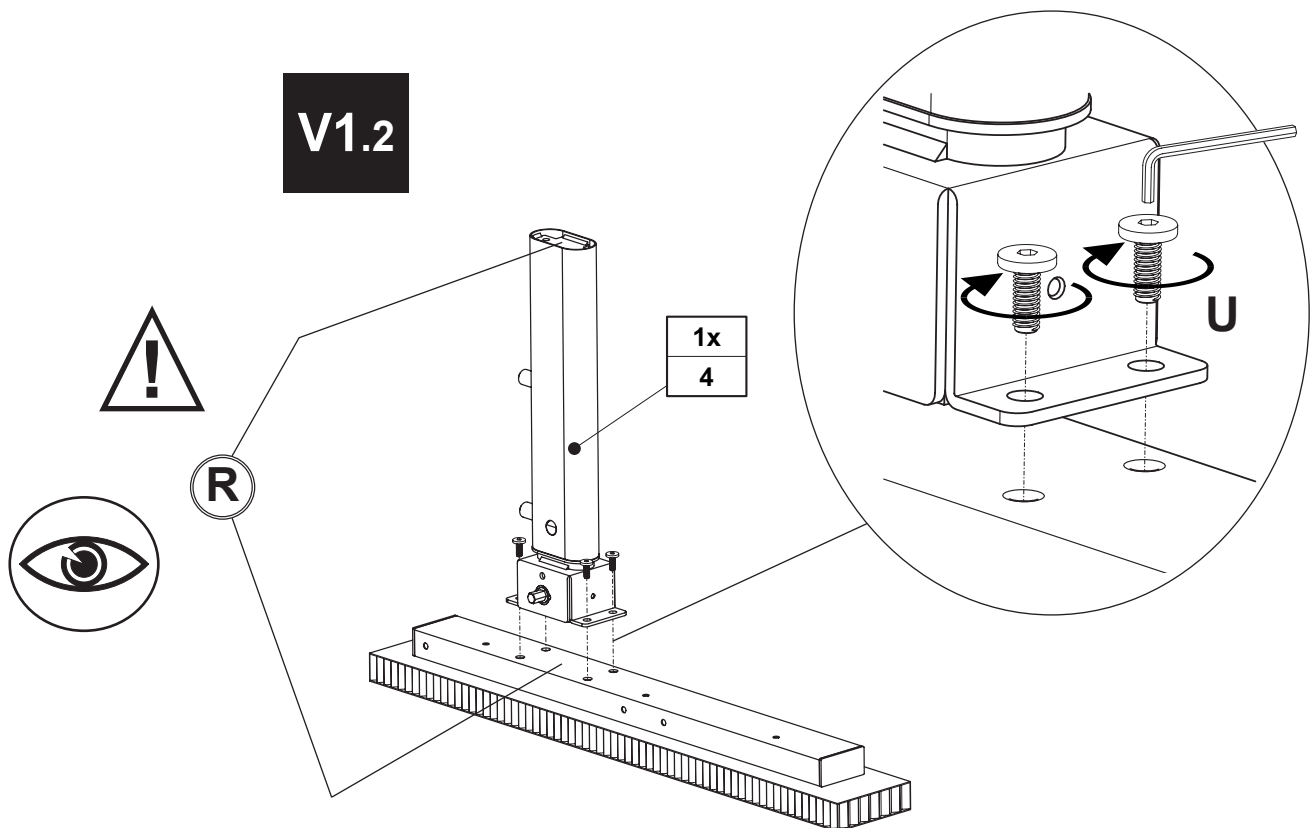

U	
M6 x 15 4x 670 0001	SW4 lang 1x 681 3010

V1.3

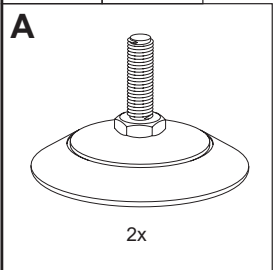
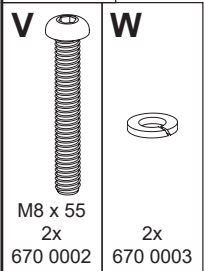
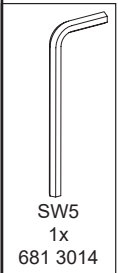
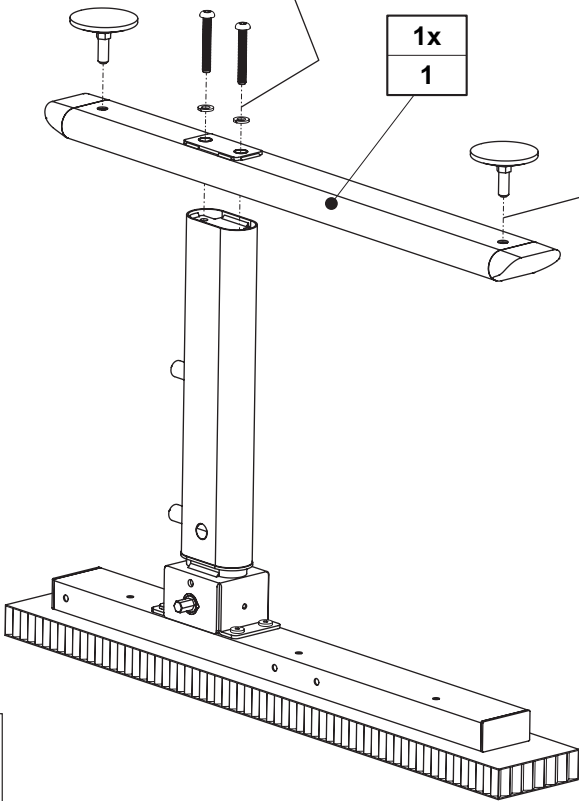
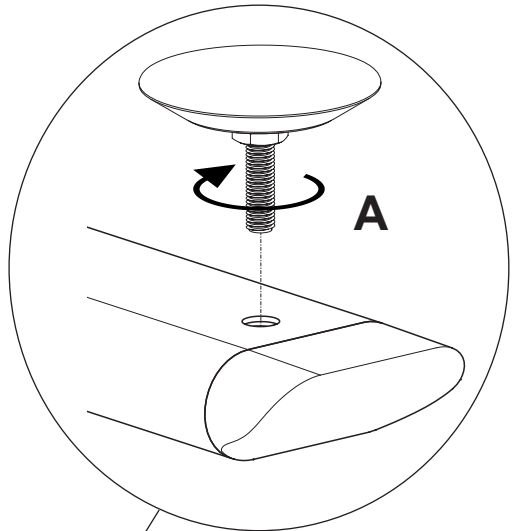
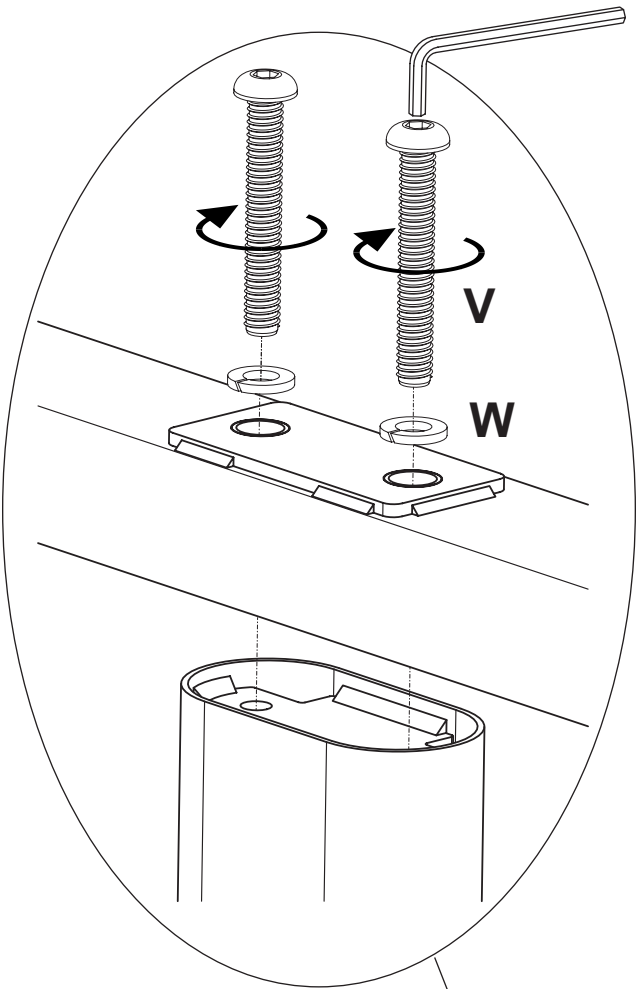

V2

V2.1



L

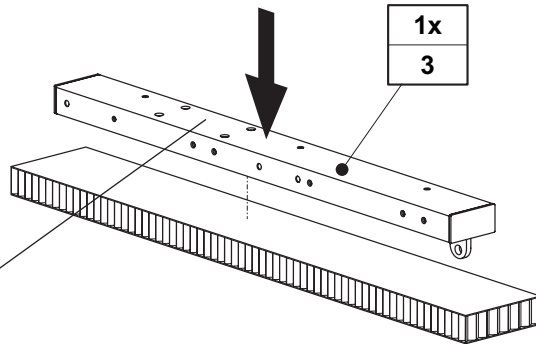

V2.2



L

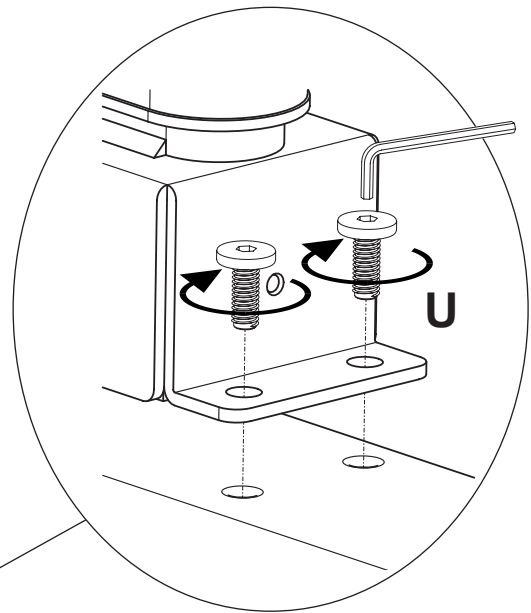
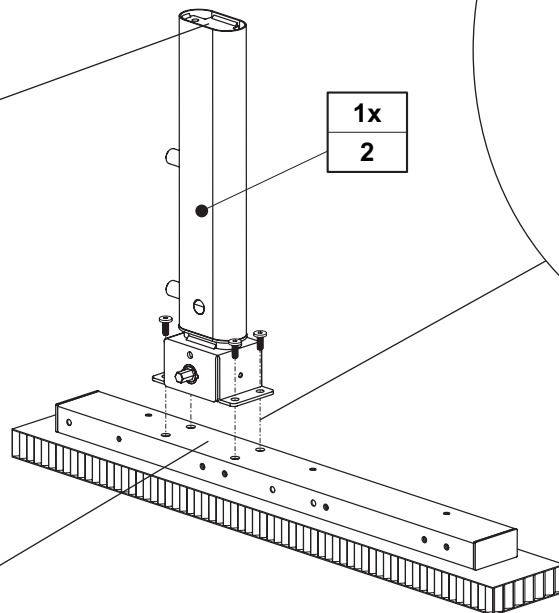

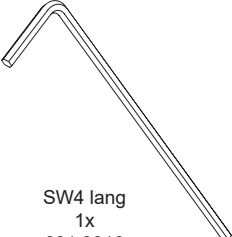
U  M6 x 15 4x 670 0001	 SW4 lang 1x 681 3010
--	---

V2.3

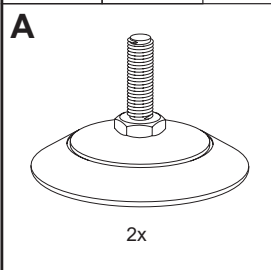
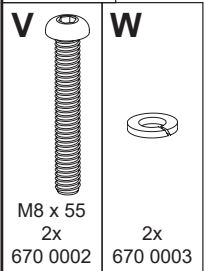
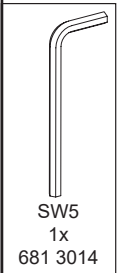
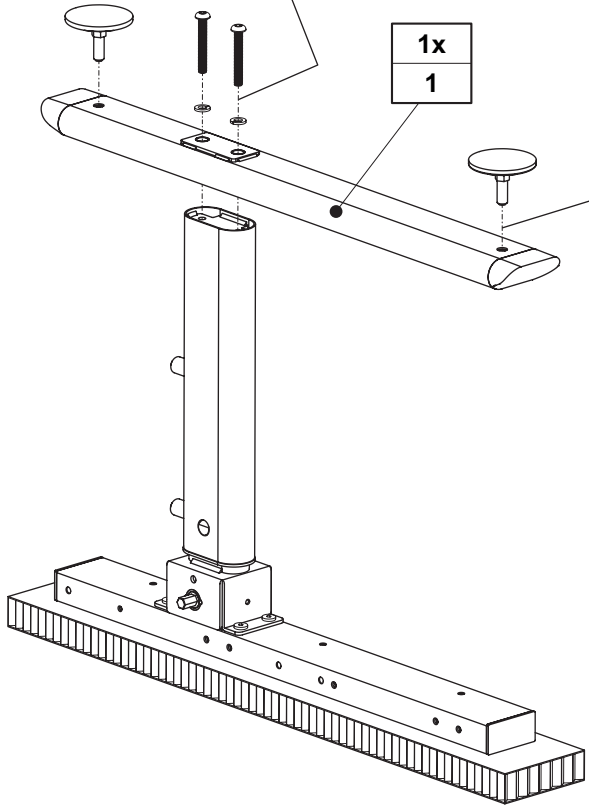
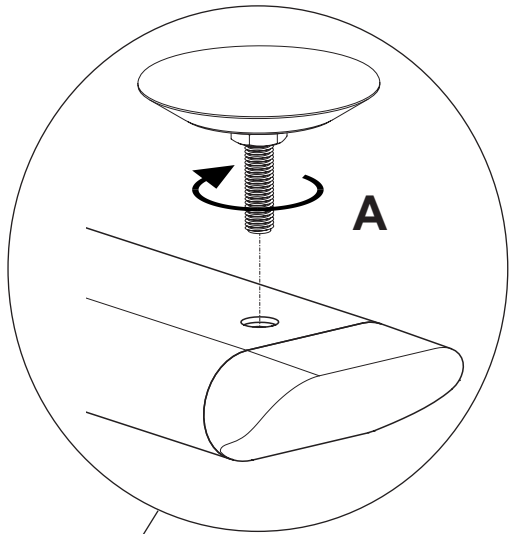
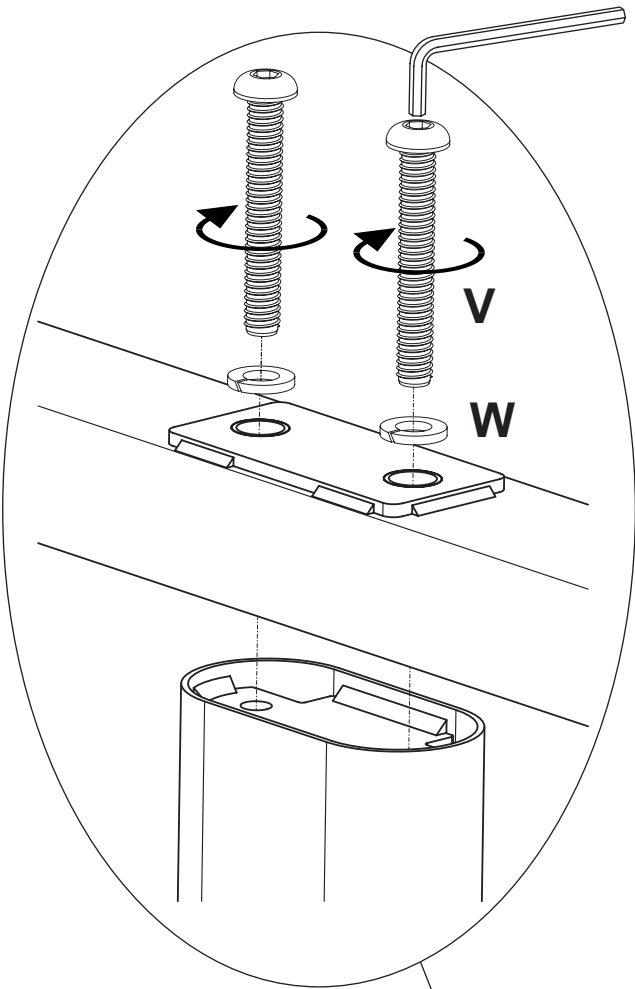



Platte „Links“



Platte „Rechts“

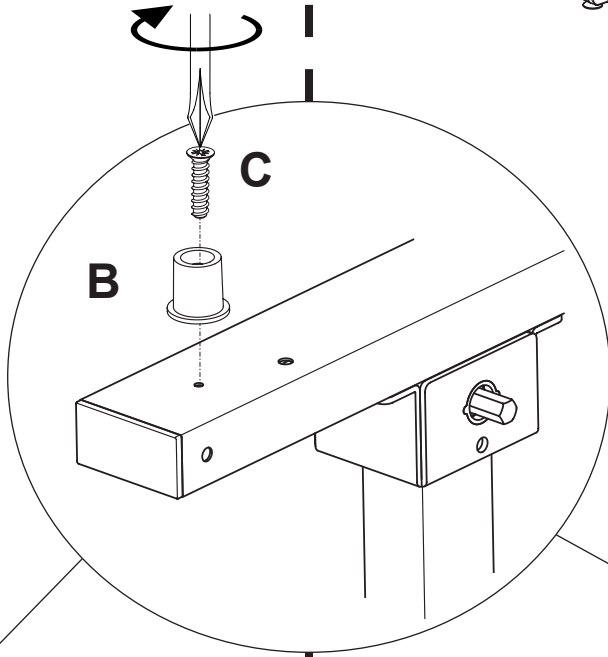
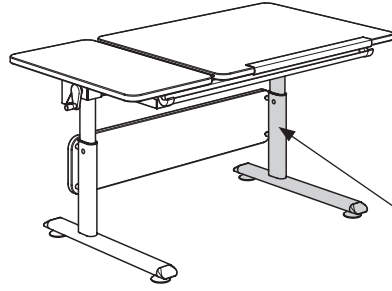
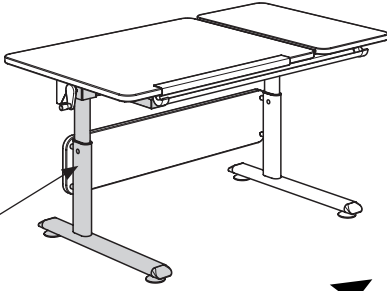

(L)



(R)

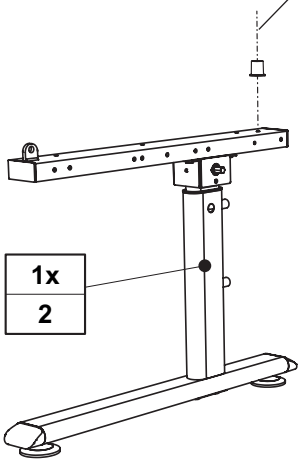

1x
2

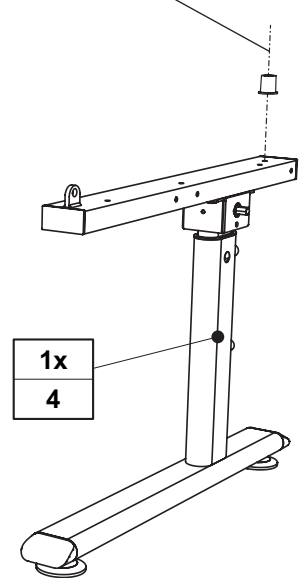
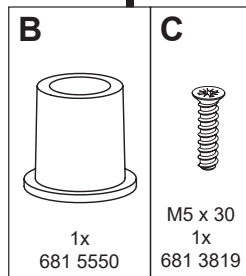

1x
4

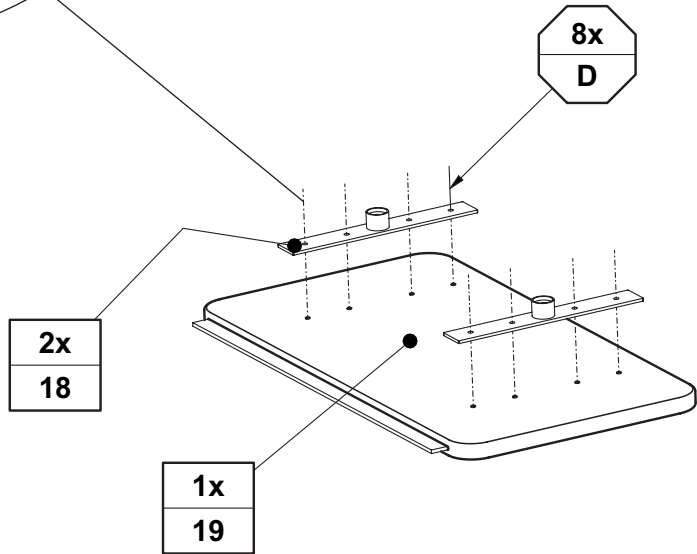
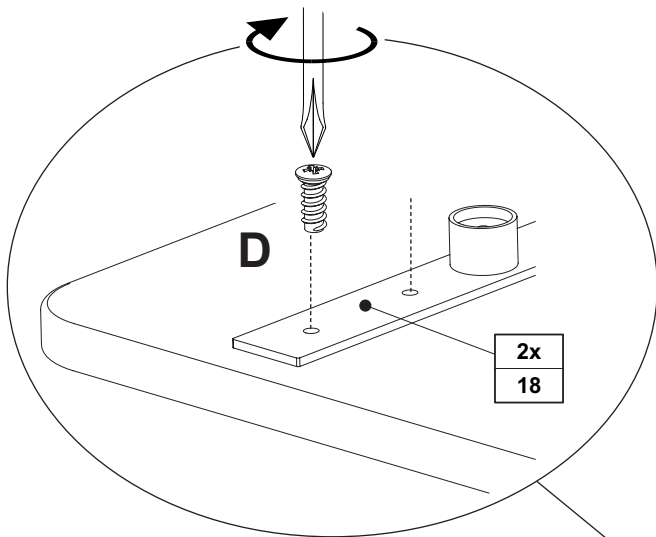

V5

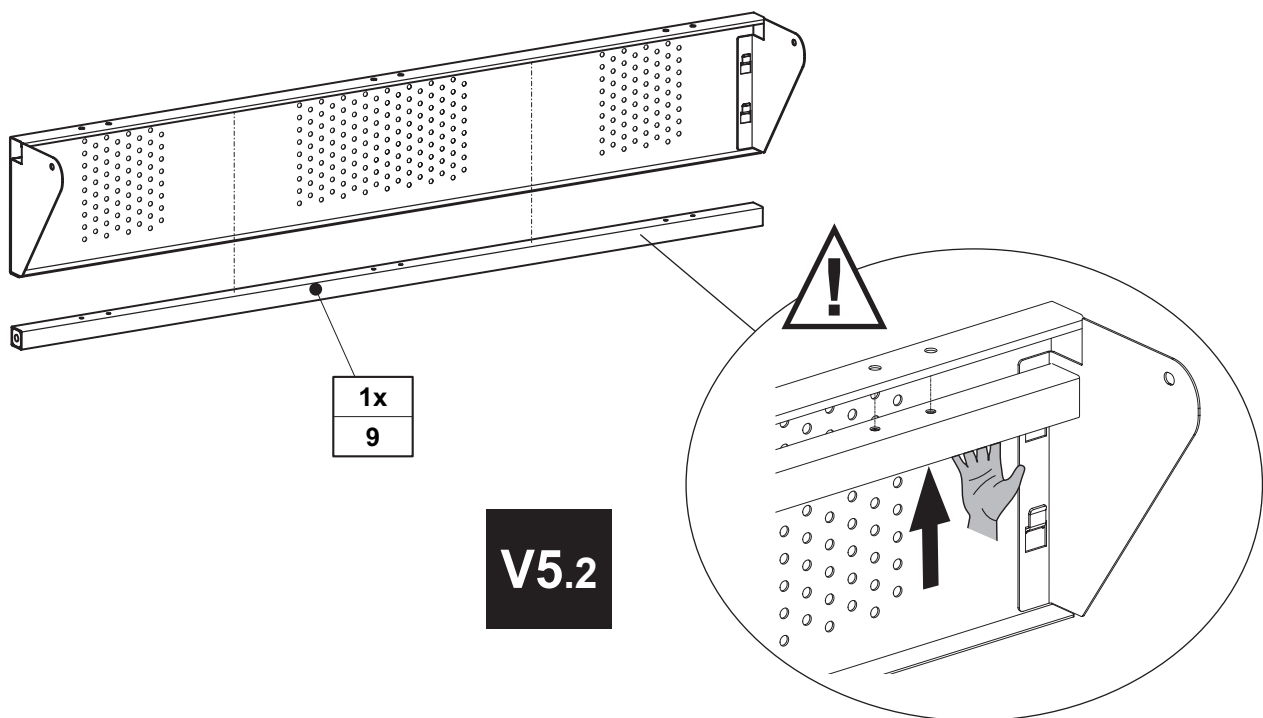
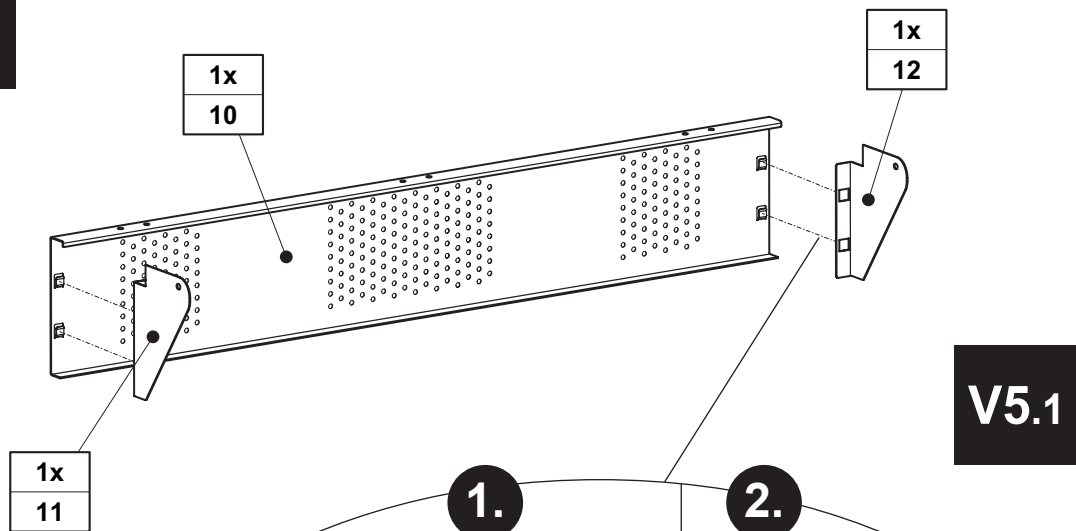



Platte „Rechts“

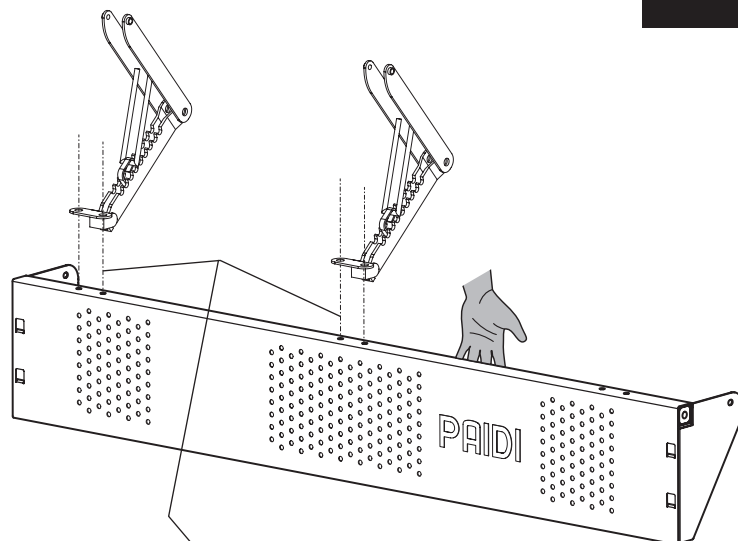
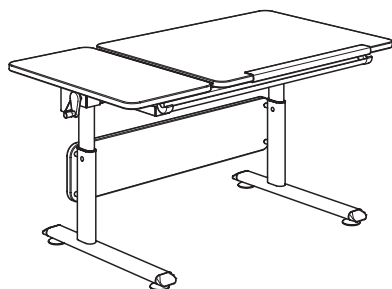

V5.3

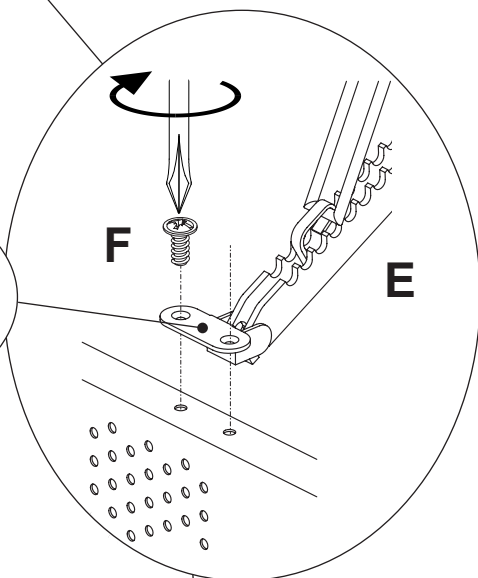
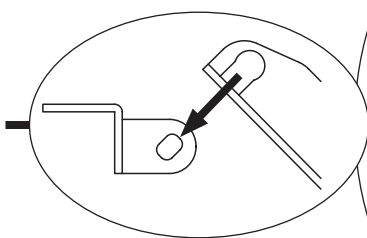
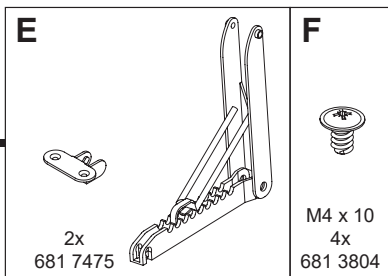

Platte „Links“

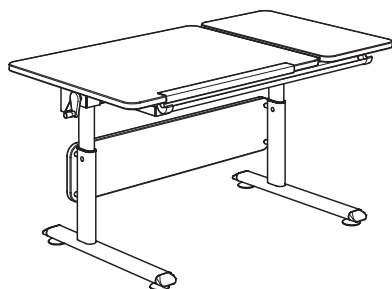

V5.3

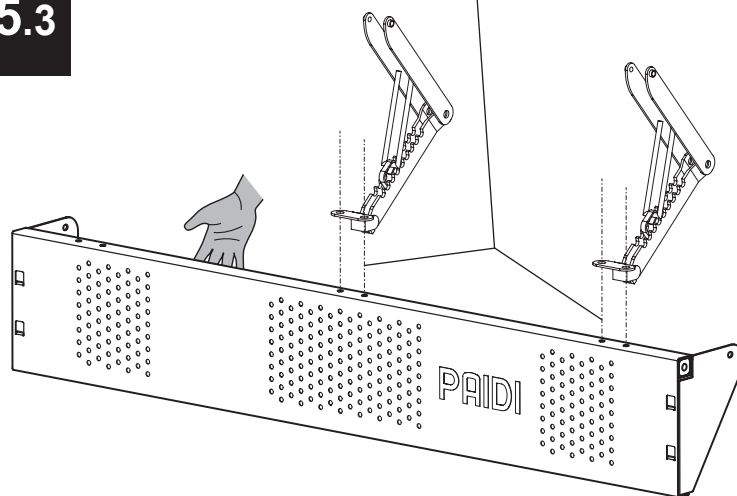

V6

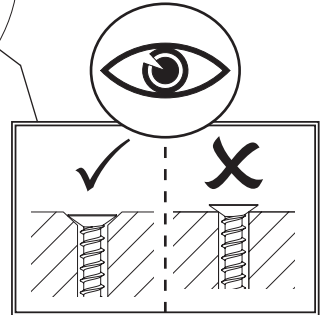
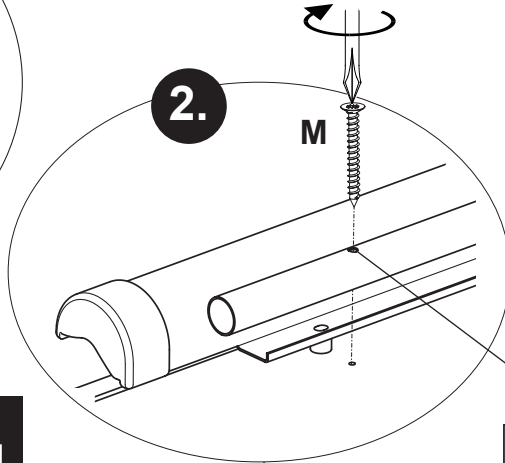
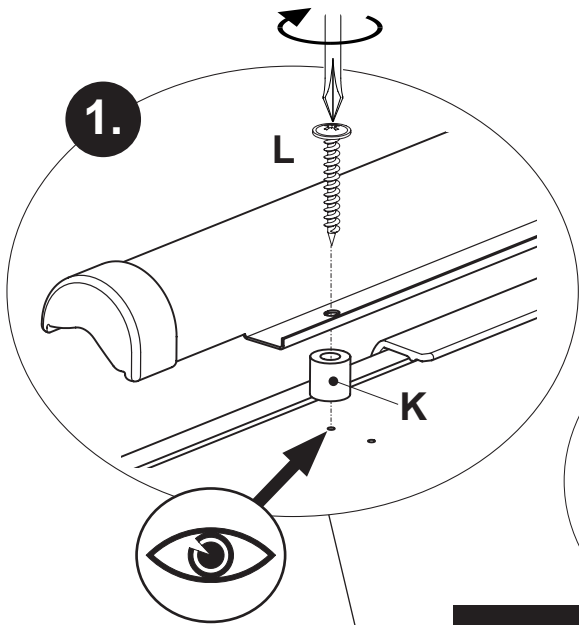
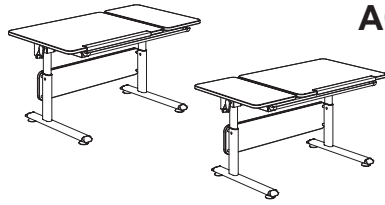

ACHTUNG! Aufbau ohne Schubkasten

PLEASE NOTE! Construction **without** drawer
ATTENTION ! Structure **sans** tiroir
LET OP! Opbouw **zonder** lades
ВНИМАНИЕ! Монтаж **без** выдвижного ящика
请注意! 无储物盒的装配
FIGYELEM! Összeszerelés fiók **nélkül**

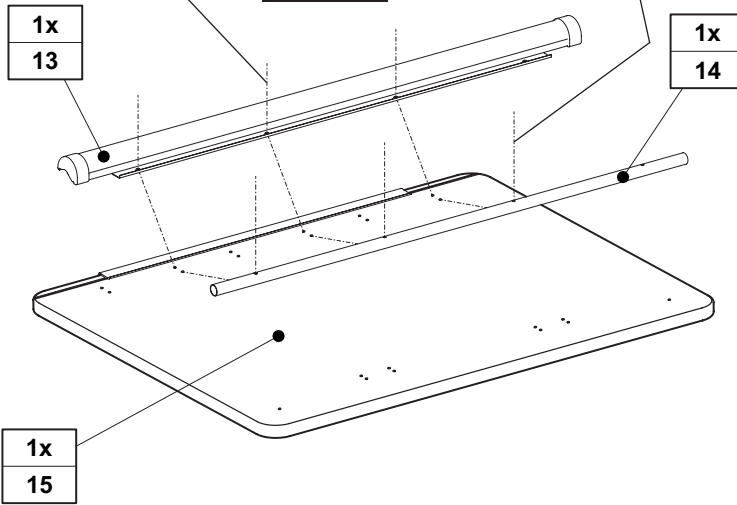

V6.1



K	L	M
		
3x 681 7047	4,0 x 35 3x 681 4909	4 x 35 3x 681 5001

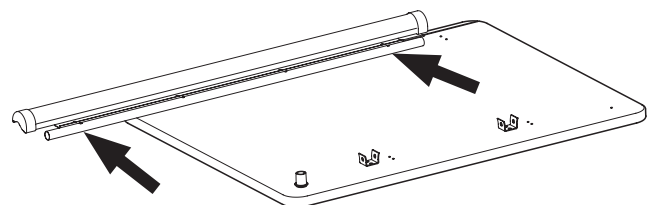
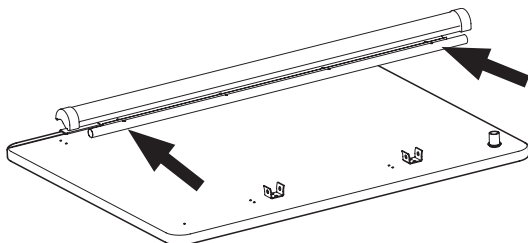
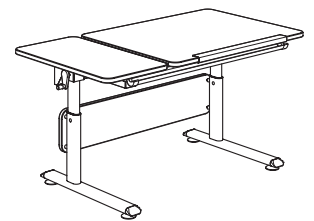
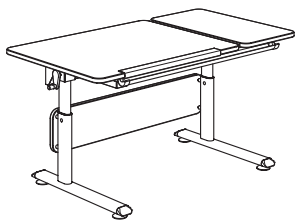

ACHTUNG! Aufbau mit Schubkasten

V6

PLEASE NOTE! Construction with drawer
ATTENTION! Structure avec tiroir
LET OP! Opbouw met schuiflade
ВНИМАНИЕ! Монтаж с выдвижным ящиком
请注意! 带储物盒的装配
FIGYELEM! Összeszerelés fiókkal

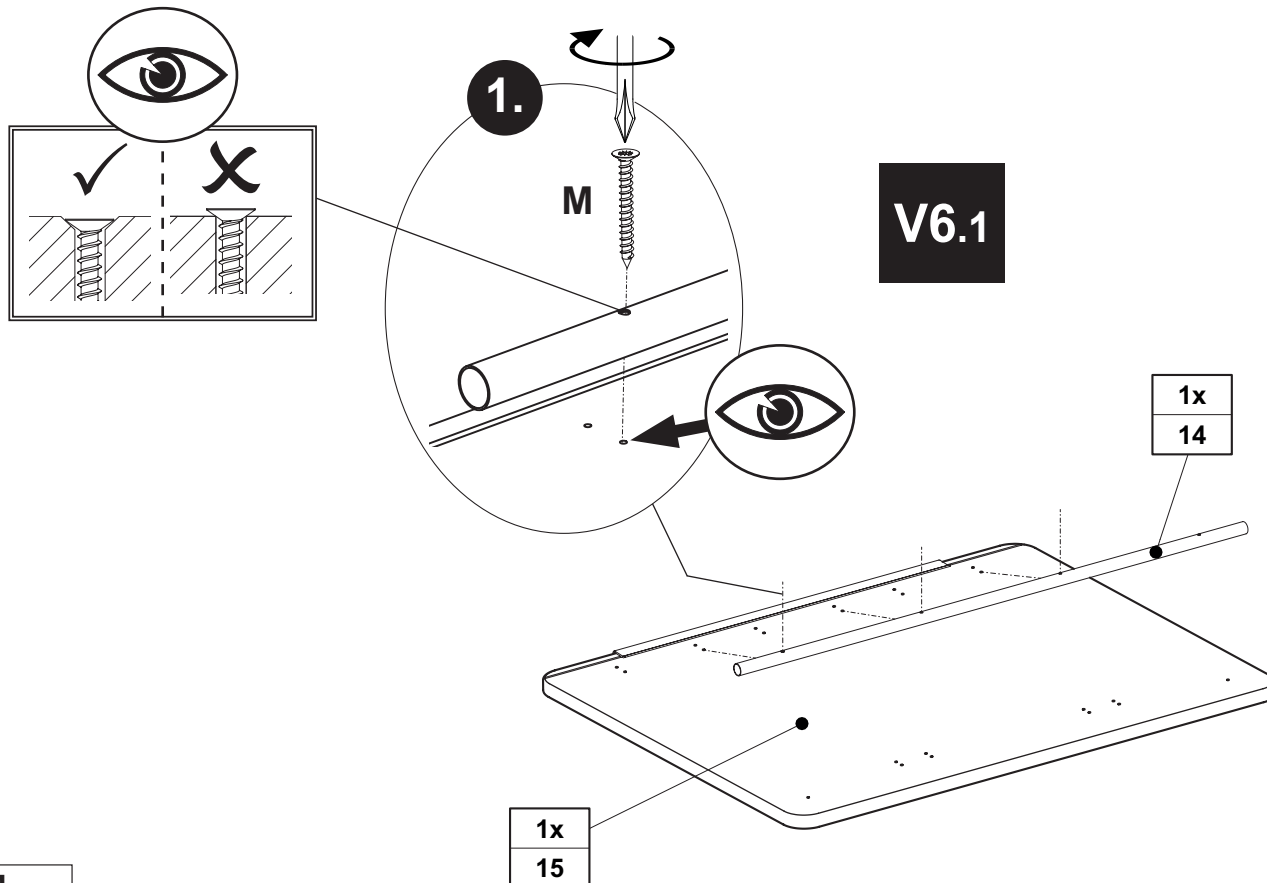
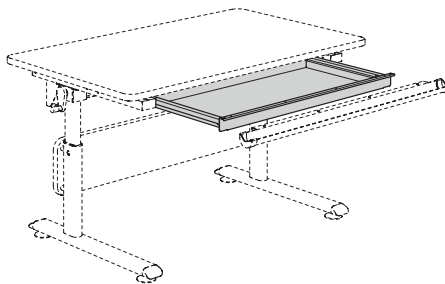

M

4 x 35
3x
681 5001

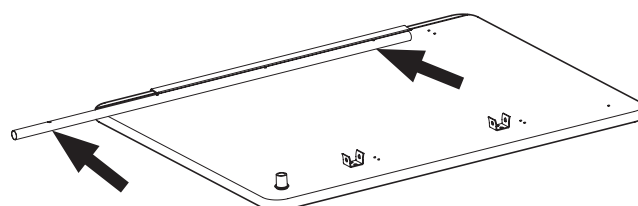
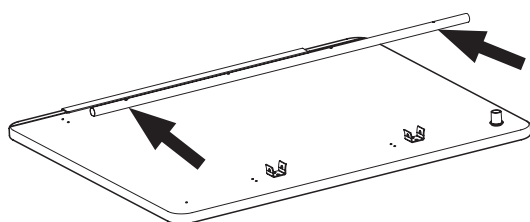
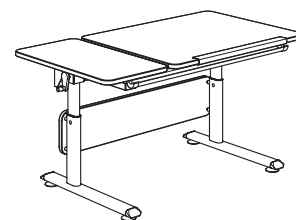
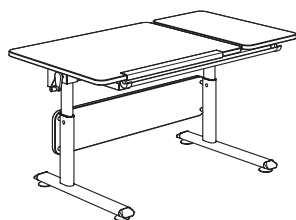

V6



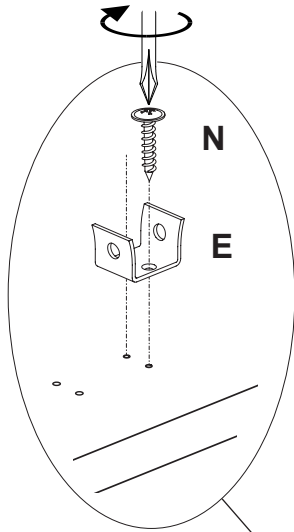
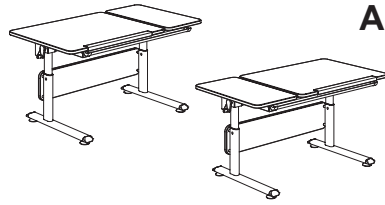

ACHTUNG! Aufbau ohne Schubkasten

PLEASE NOTE! Construction **without** drawer
ATTENTION ! Structure **sans** tiroir
LET OP! Opbouw **zonder** lades
ВНИМАНИЕ! Монтаж **без** выдвижного ящика
请注意! 无储物盒的装配
FIGYELEM! Összeszerelés fiók **nélkül**

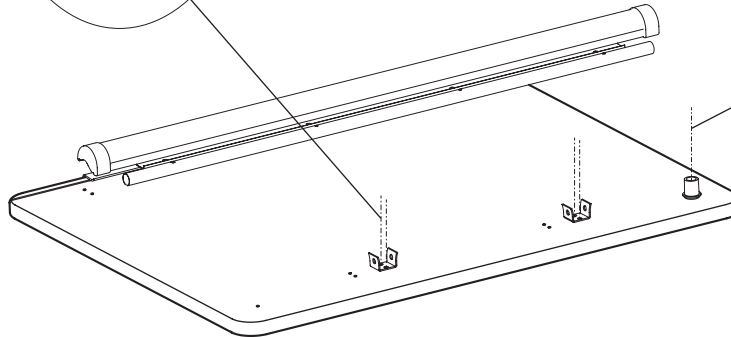
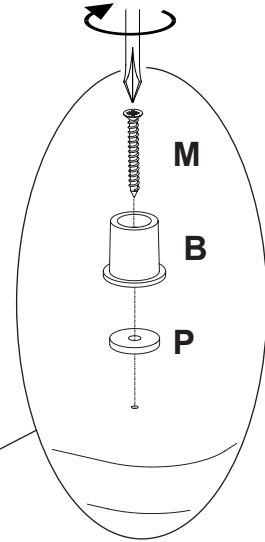

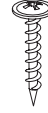
V6.2

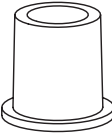

N	E	B	P	M
				
4,0 x 20 4x 681 4917	2x 681 7475	1x 681 5550	1x 681 7494	4 x 35 1x 681 5001

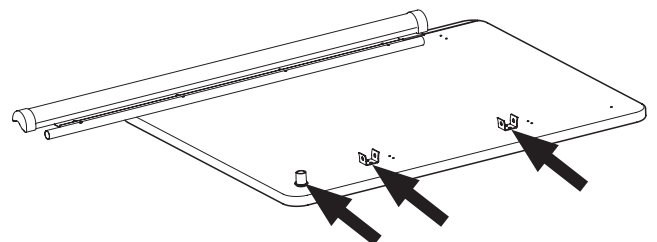
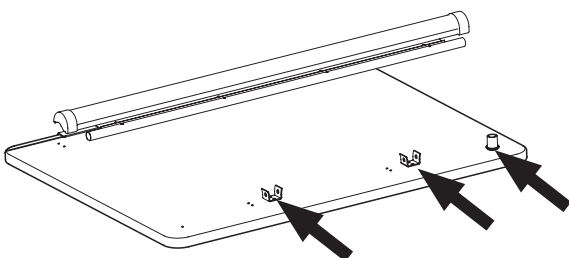
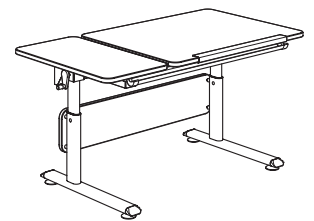
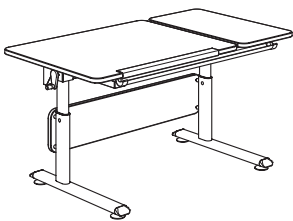

ACHTUNG! Aufbau mit Schubkasten

V6

PLEASE NOTE! Construction with drawer
 ATTENTION! Structure avec tiroir
 LET OP! Opbouw met schuiflade
 ВНИМАНИЕ! Монтаж с выдвижным ящиком
 请注意! 带储物盒的装配
 FIGYELEM! Összeszerelés fiókkal

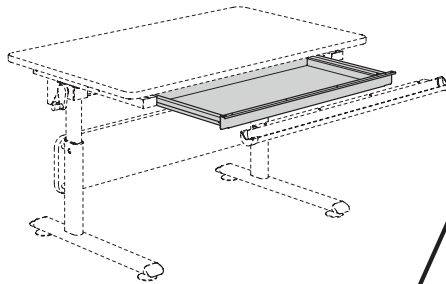

Montage Schubkasten auf separate Gebrauchsanleitung !!

The drawer assembly is on **separate** instructions for use!
 Le montage des tiroirs est expliqué dans un mode d'emploi **séparé!**

Montage lades op **aparte** gebruiksaanwijzing!
 Сборка выдвижного ящика описана в **отдельной**
 инструкции!
 根据单独的说明组装抽屉!
 Összeszerelés fiókkal **külön** használati utasításban!

PK-Nr. 1421 / 1424

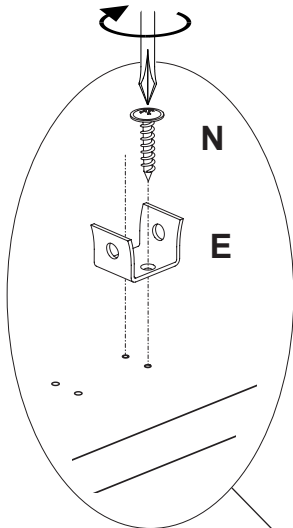

V6.2

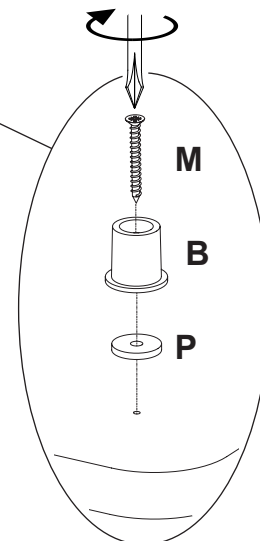
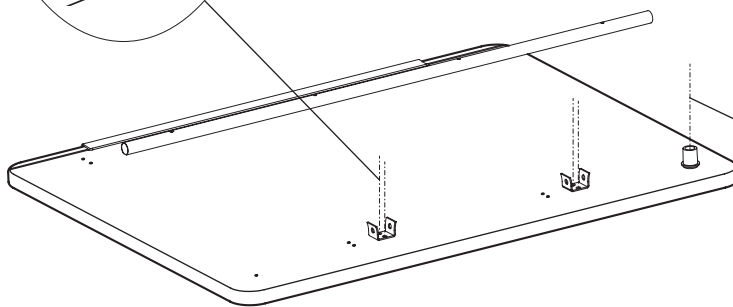

N	E	B	P	M
4,0 x 20 4x 681 4917	2x 681 7475	1x 681 5550	1x 681 7494	4 x 35 1x 681 5001

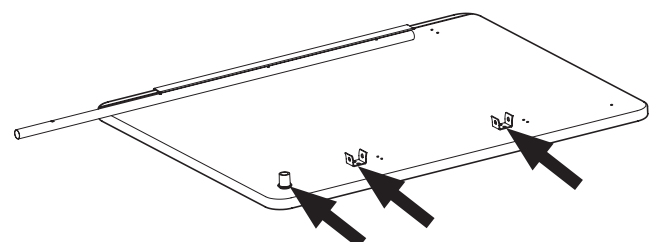
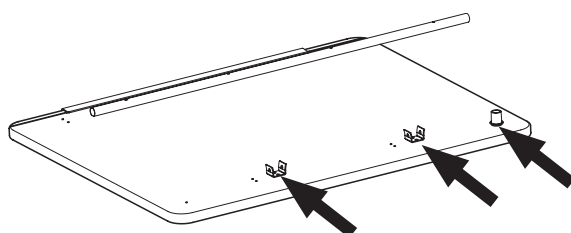
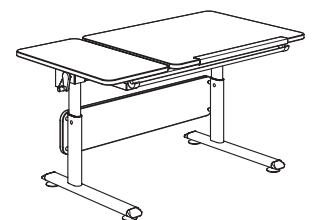
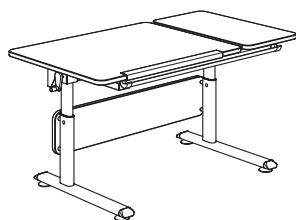

Seite 21 von 28

PK-Nr. 2797 Stand 09/2018 Ä: 05/2025

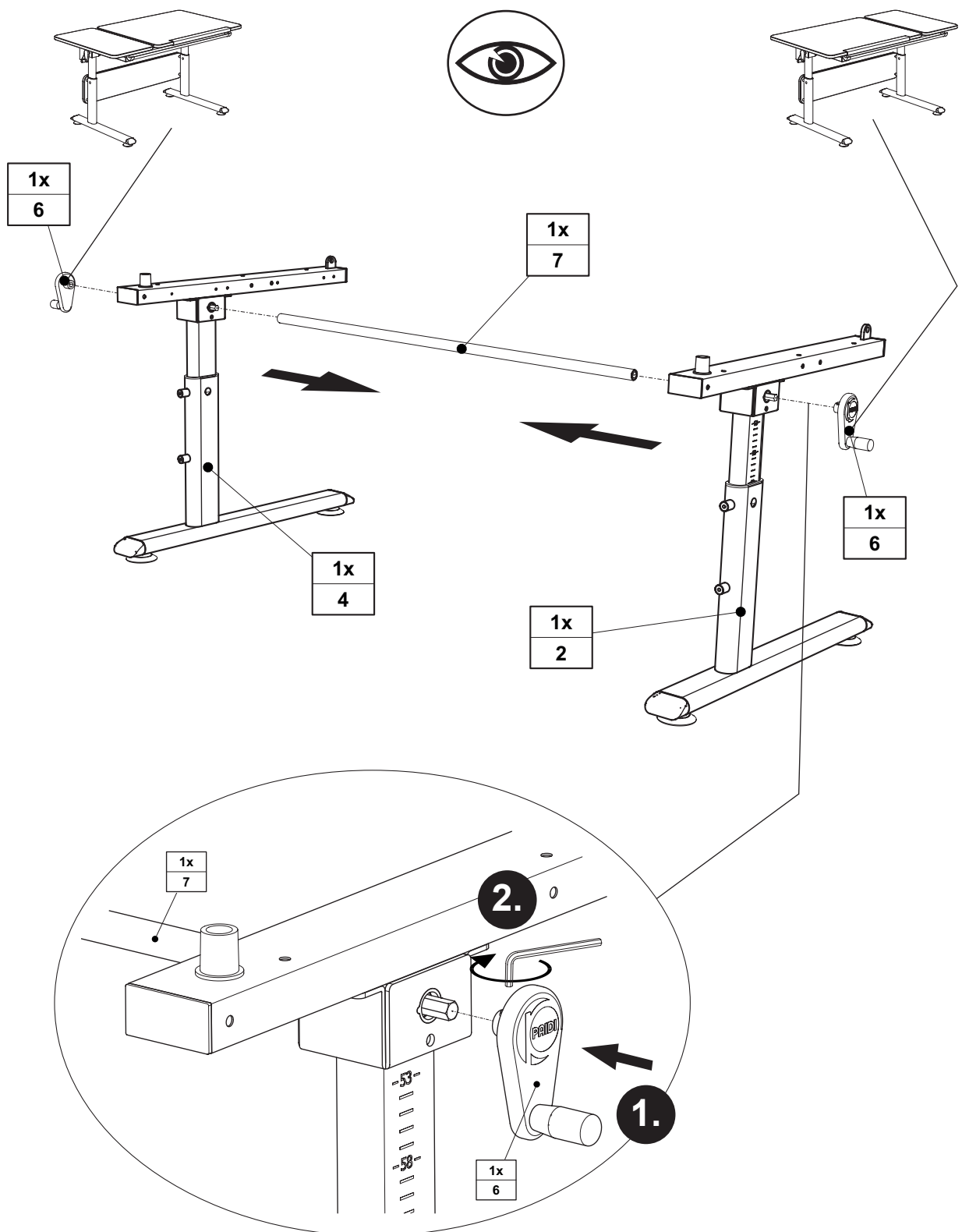

M2

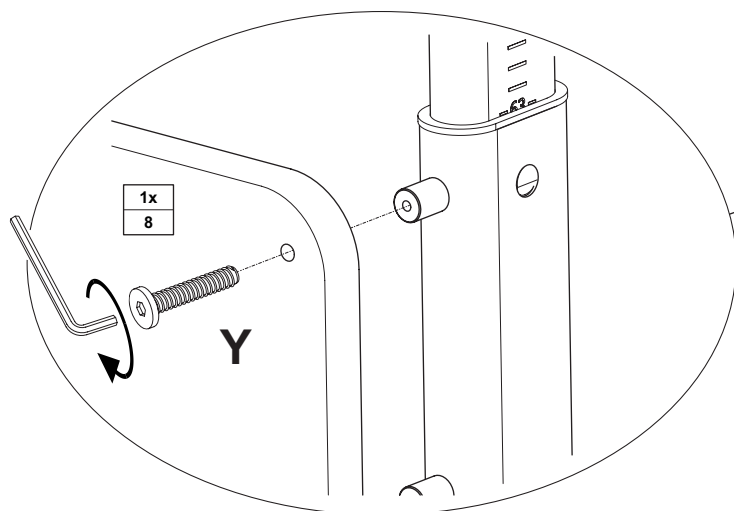
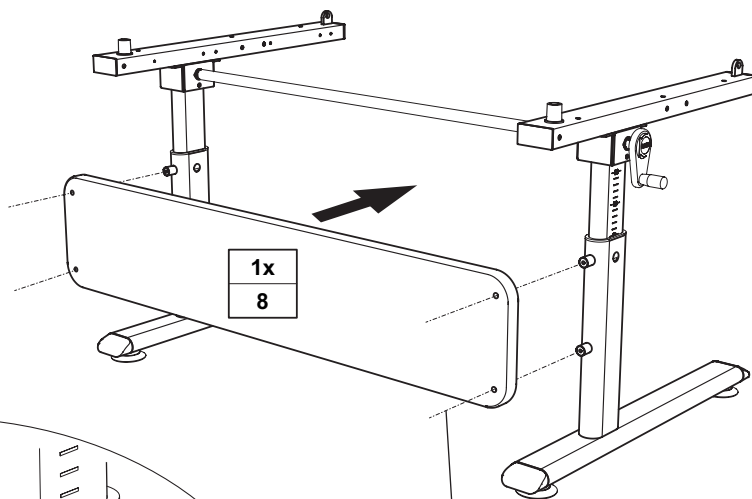
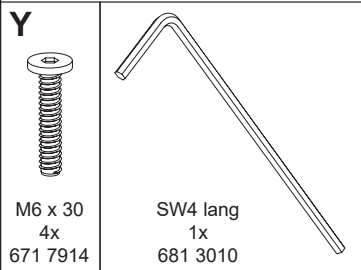

M3

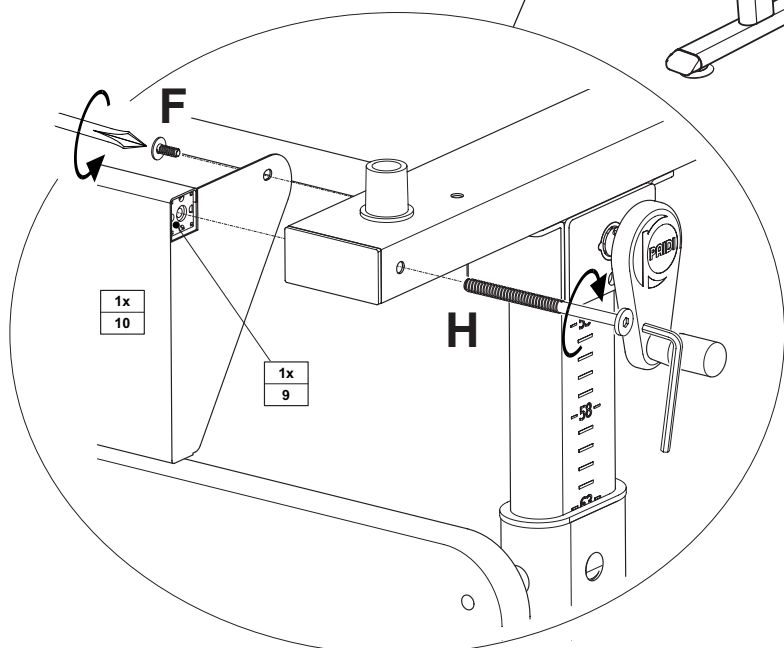
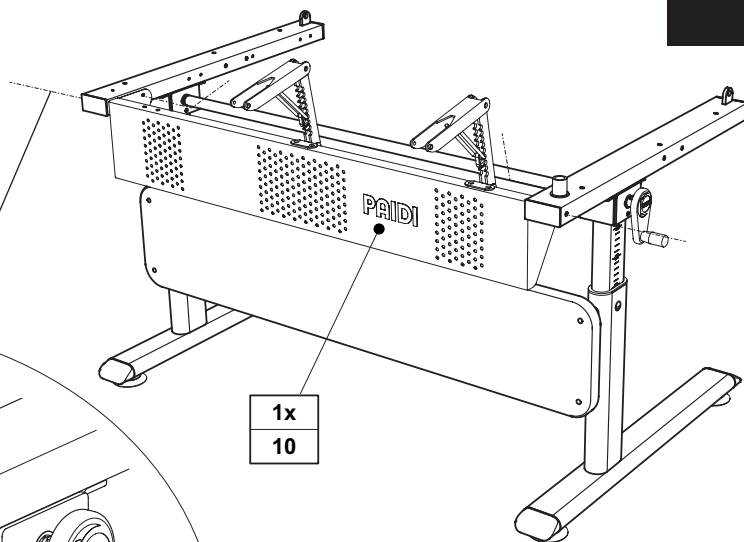
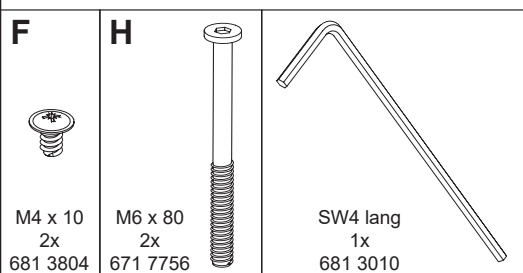

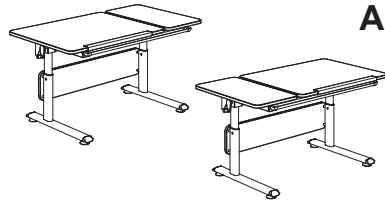

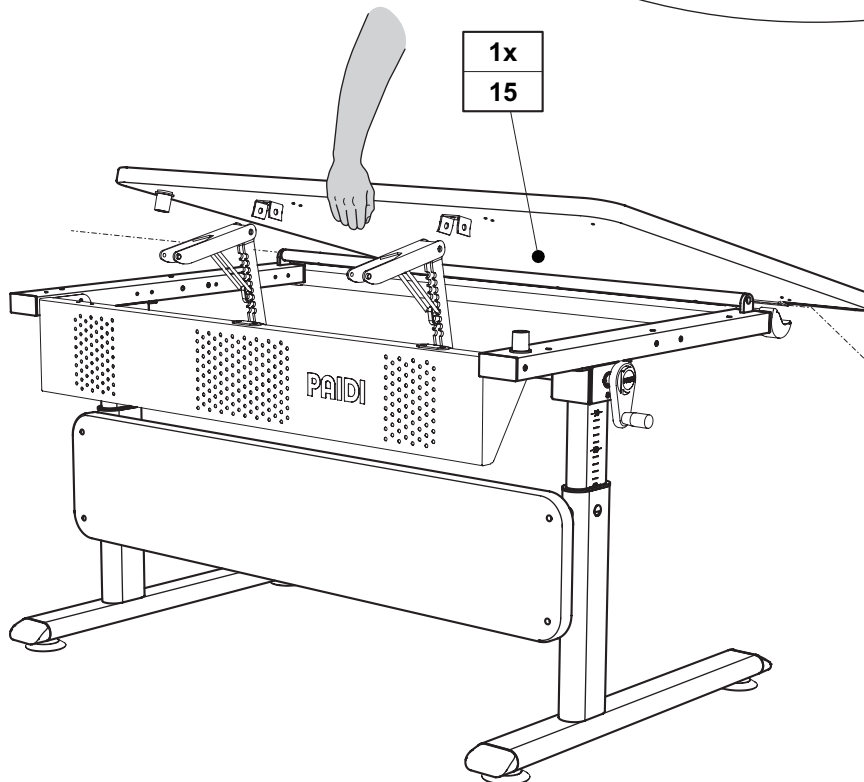
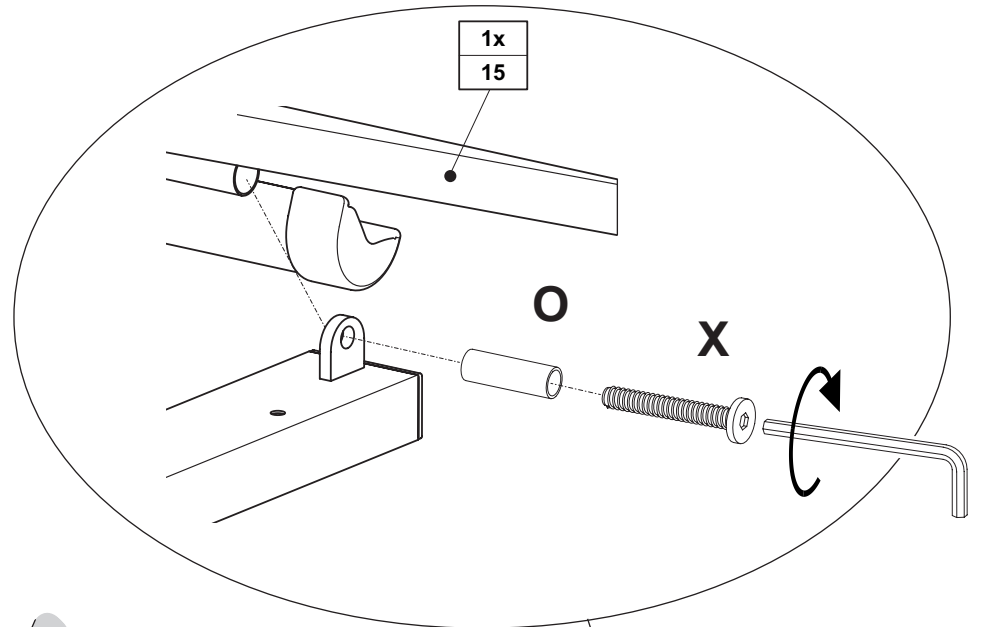

ACHTUNG! Aufbau ohne Schubkasten

PLEASE NOTE! Construction **without** drawer
 ATTENTION ! Structure **sans** tiroir
 LET OP! Opbouw **zonder** lades
 ВНИМАНИЕ! Монтаж **без** выдвижного ящика
 请注意! 无储物盒的装配
 FIGYELEM! Összeszerelés fiók **nélkül**

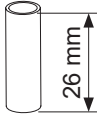

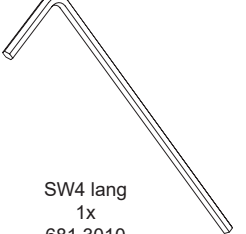

<p>O</p>  <p>26 mm</p>	<p>X</p> 	
<p>2x 671 7762</p>	<p>M6 x 40 2x 671 7755</p>	<p>SW4 lang 1x 681 3010</p>

ACHTUNG! Aufbau mit Schubkasten

PLEASE NOTE! Construction with drawer
ATTENTION! Structure avec tiroir
LET OP! Opbouw met schuiflade
ВНИМАНИЕ! Монтаж с выдвижным ящиком
请注意! 带储物盒的装配
FIGYELEM! Összeszerelés fiókkal

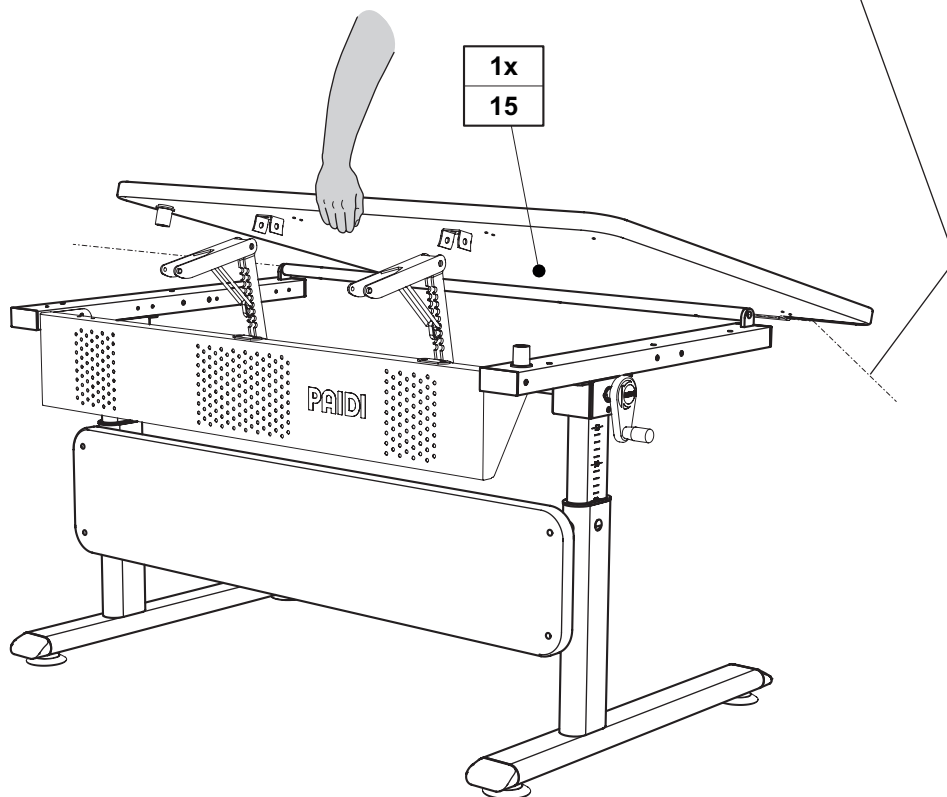
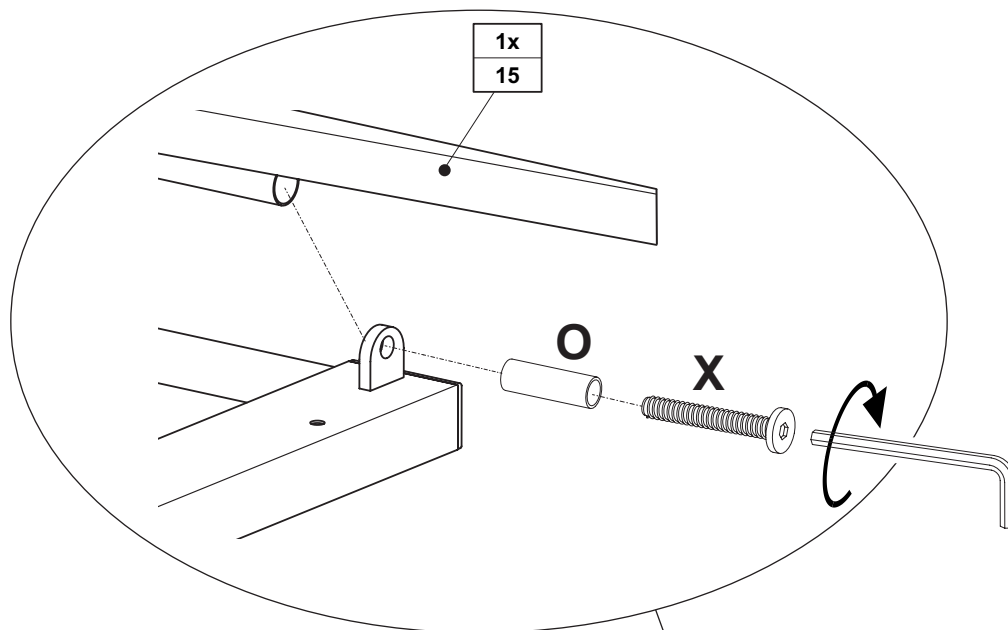
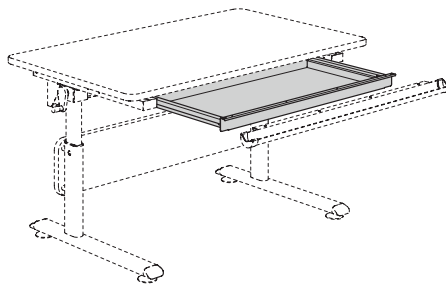
M4

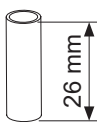

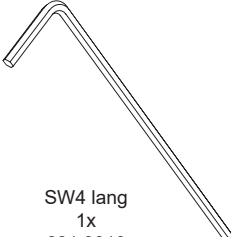
O  26 mm 2x 671 7762	X  M6 x 40 2x 671 7755	 SW4 lang 1x 681 3010
---	--	---

M5

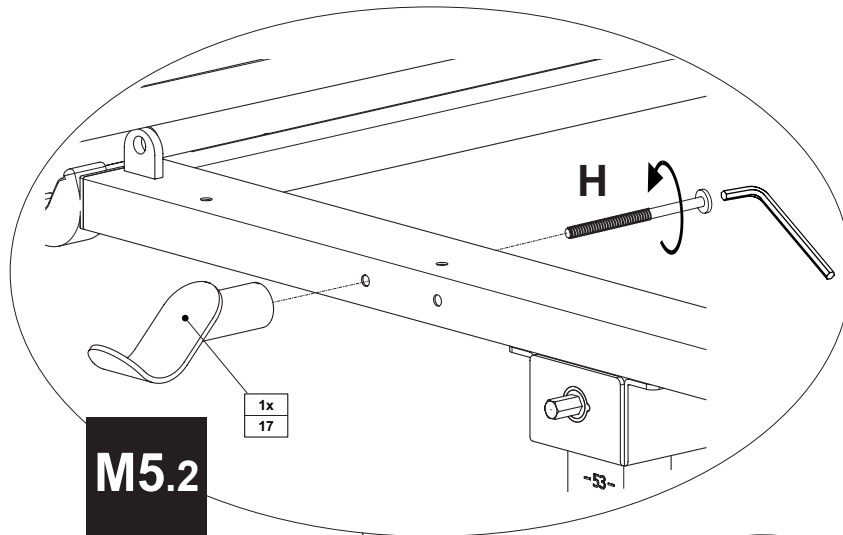
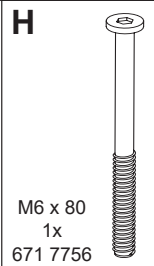
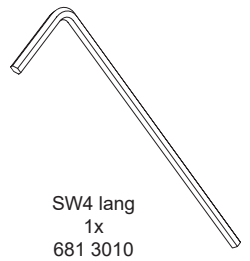

1x
17

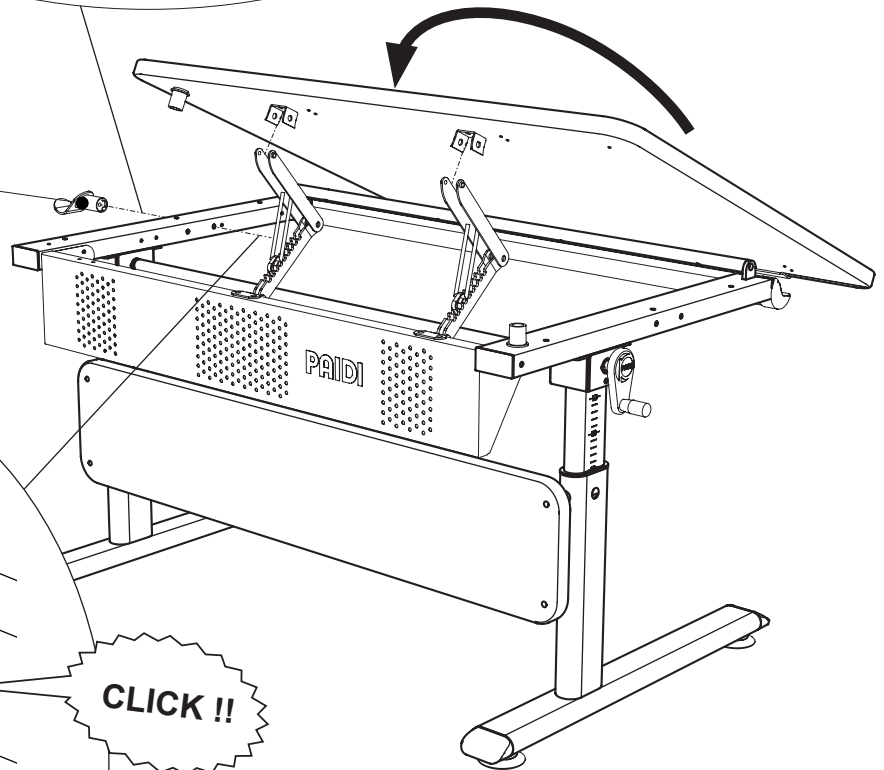

M5.1

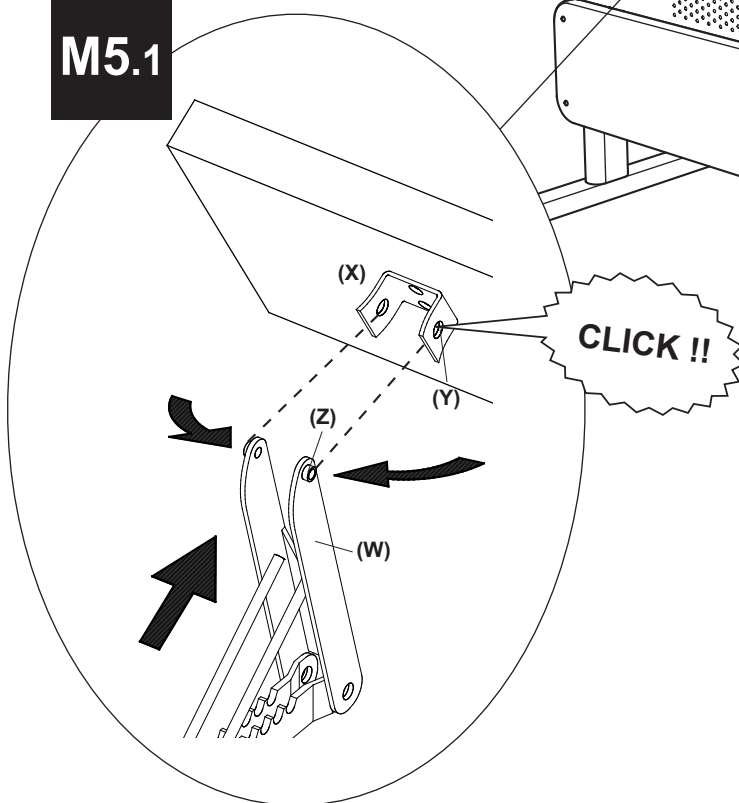

DE: Rasterschere (W) auf das Anschraubteil (X) aufschieben, so dass die Bohrungen (Y) in die Bolzen (Z) einrasten.

GB: Slide the ratchet stay (W) onto the screw-on part (X) so that the holes (Y) engage in the bolts (Z).

FR: Pousser l'articulation encastrable (W) sur la pièce à visser (X) de telle façon que les trous (Y) s'encastrent dans les boulons (Z).

NL: Schuif het schaarmechanisme (W) zo op het aanschroefstuk (X) dat de openingen (Y) in de bouten (Z) vastklikken.

RU: Надвиньте кронштейн с фиксатором (W) на привинчиваемую часть (X), чтобы отверстия (Y) попали в пальцы (Z).

CN: 将升降配件 (W) 推到螺钉连接的部件 (X) 上, 以使孔 (Y) 与螺栓 (Z) 相啮合。

HU: Toljuk rá a könyökös tartót (W) a csavaros részre (X) mindaddig, amíg a furatok (Y) a csapokba (Z) be nem kattannak.

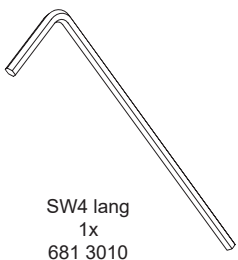
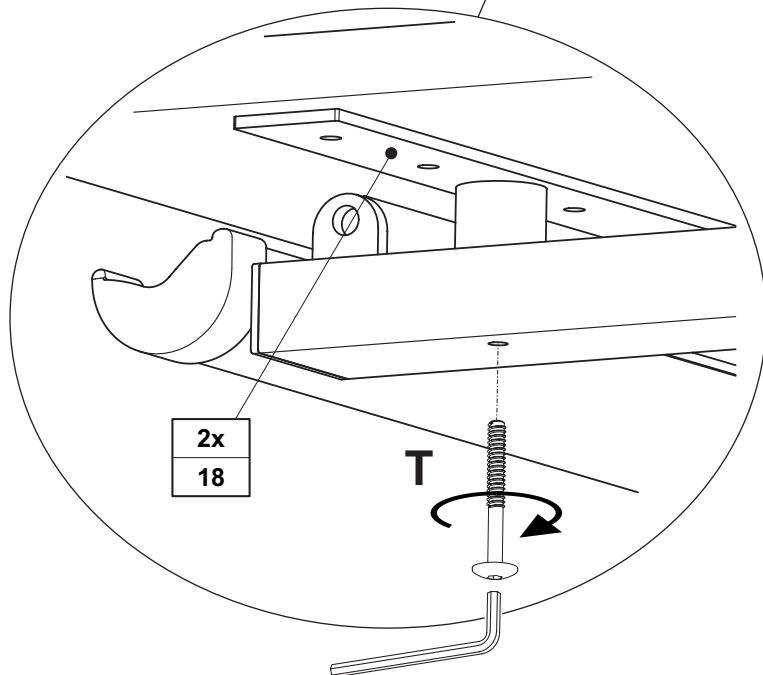
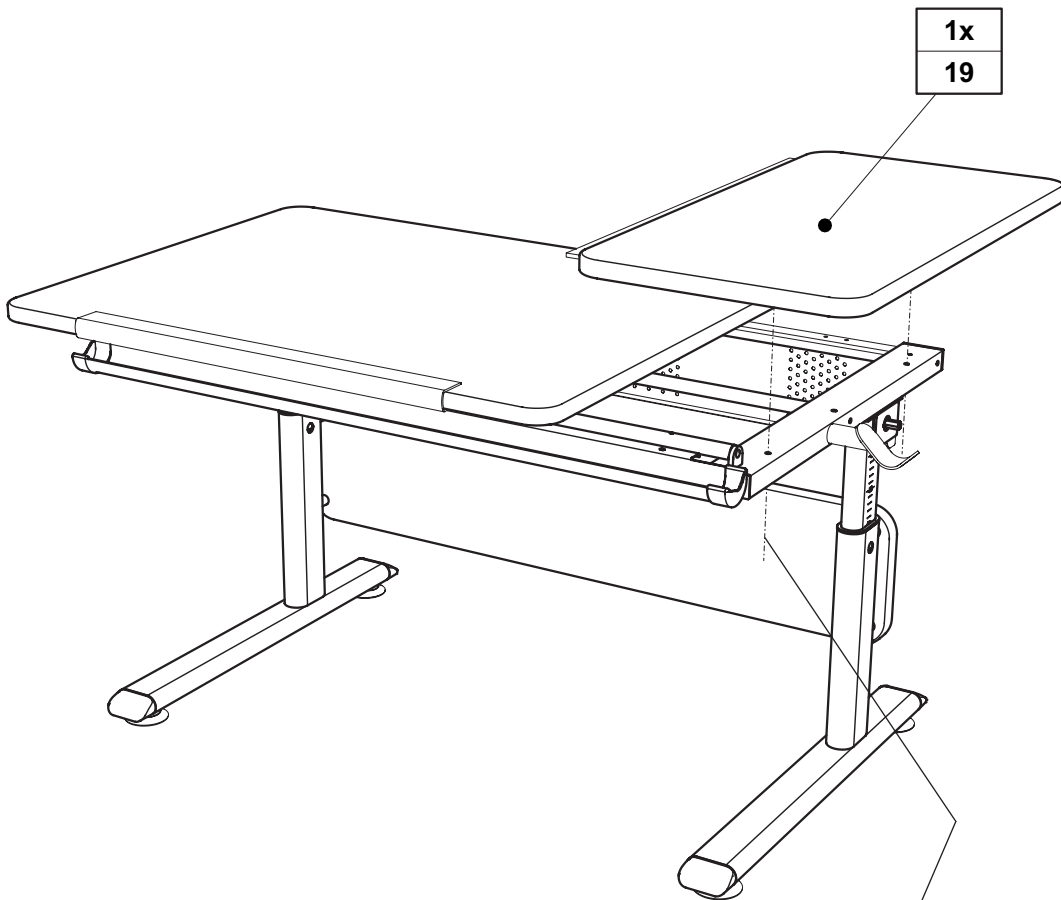

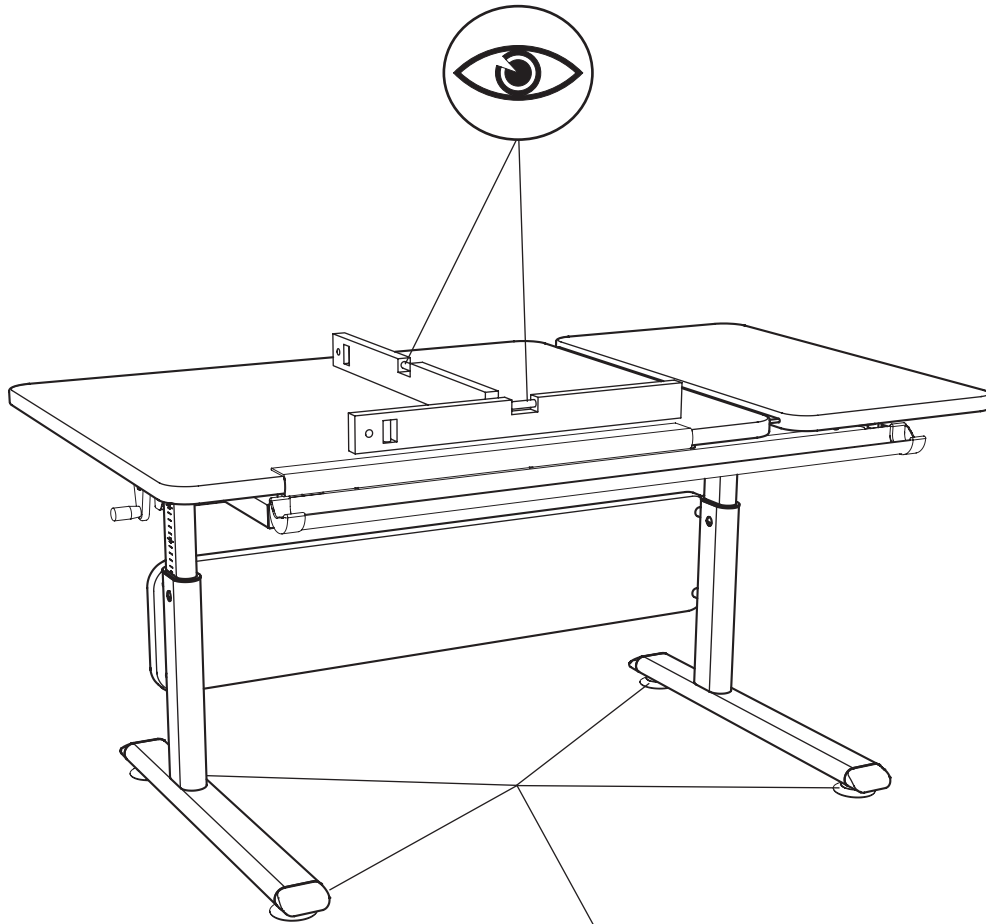

Höhenverstellung!

Height adjustment!

Réglage de la hauteur!

Hoogteverstelling!

Регулировка высоты!

高度調整!

Magasságállítás!

