

REPC-Nr.:

Service • Assistenza • Dienstverlening • Serwis
Servis • Szerviz • Сервисная служба

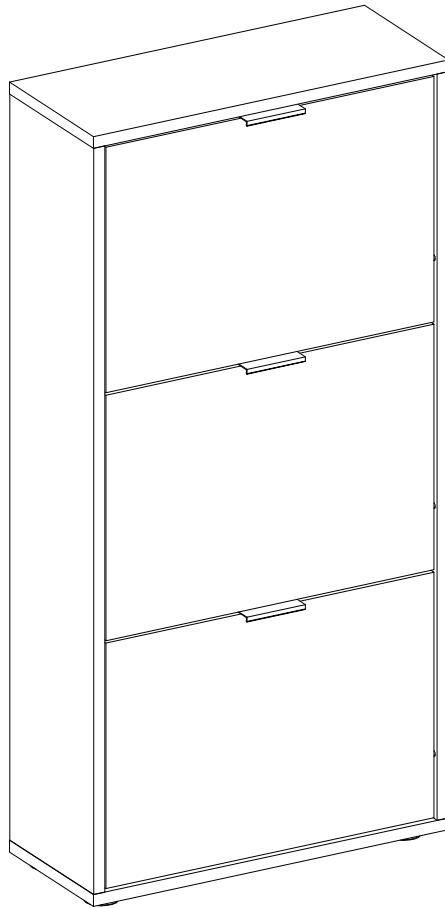

Artikel.-Nr.:

0920-SKI_003-61

Montageanleitung.-Nr.:



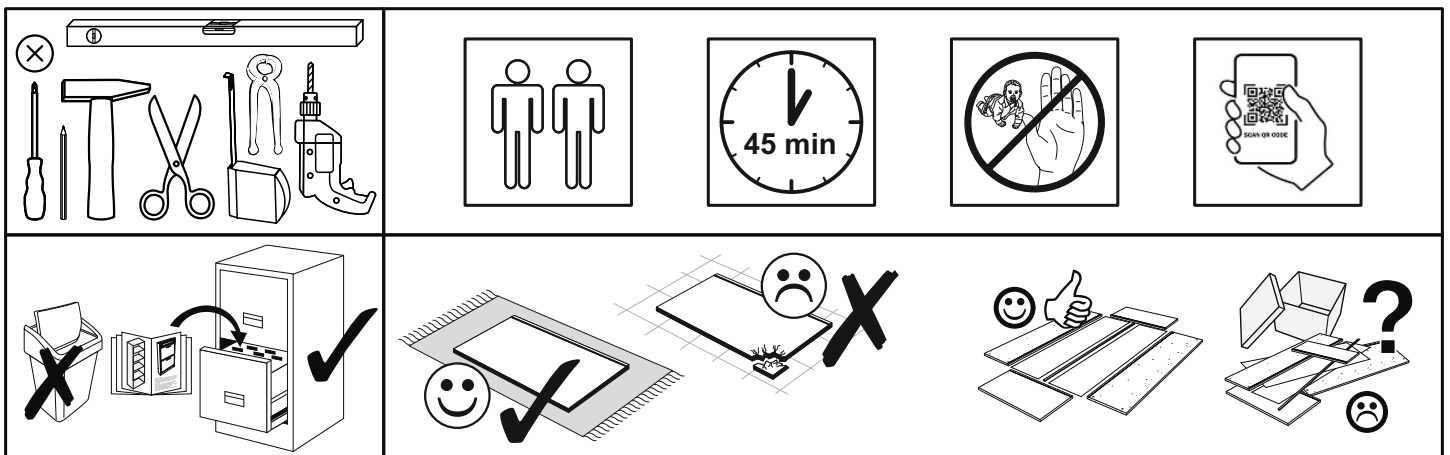

MA1-00248





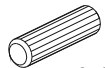
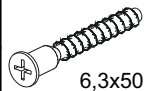

SCAN ME

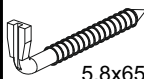
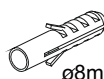
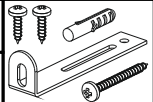
Das Ersatzteil-Anforderungsformular finden Sie auf
The replacement parts requisition form you find on
<https://www.mausbacher.de/ersatzteile/>

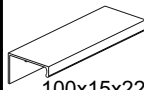
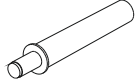
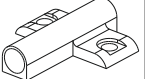

BT1-00458 Colli 1/1

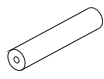
B02-10	 12x ø15x12mm	B02-20	 12x	B02-103	 2x 8x30	B01-10	 4x 6,3x50	B01-200	 24x 6,3x13	B01-80	 30x 3,5x13
B08-40	 2x 5,8x65	B08-70	 2x ø8mm	B08-80	 1x						

BT1-00459 Colli 1/1

B06-425sg	 3x 100x15x22	B03-81	 6x	B03-82	 6x	B05-174	 6x	B05-178	 6x	B05-121	 6x
-----------	--	--------	---	--------	---	---------	---	---------	---	---------	---

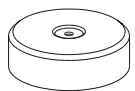
BT1-00005 Colli 1/1

B02-173	 4x		B01-123	 8x 4,0x15
---------	---	---	---------	---

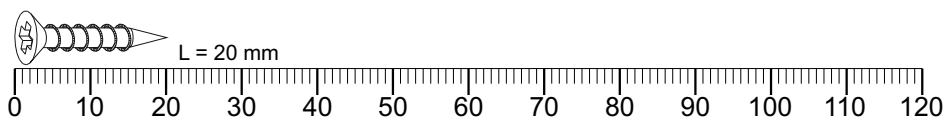

▶ SCAN ME

Colli 1/1

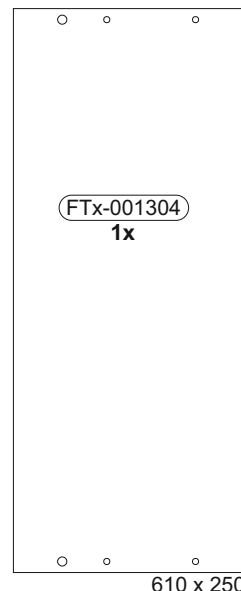
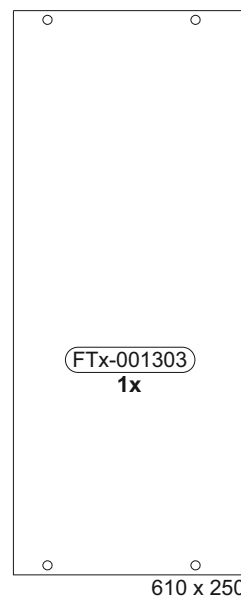
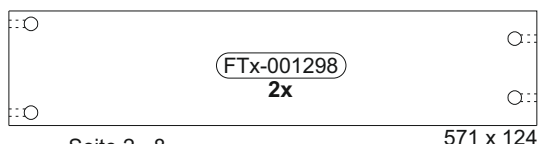
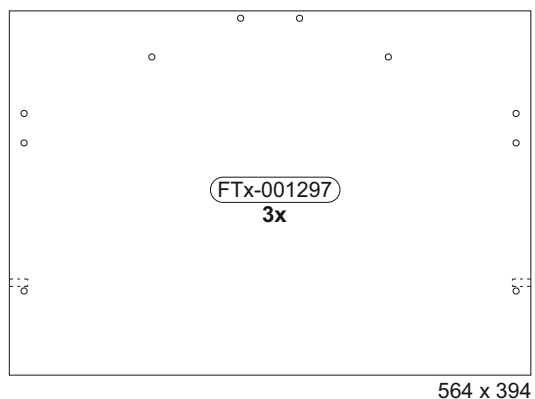
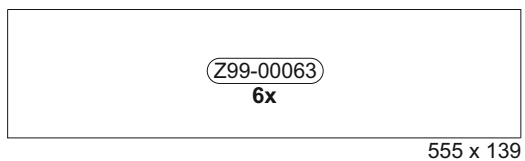
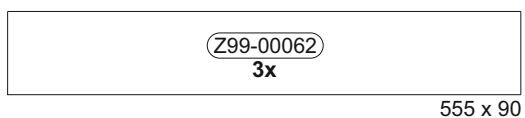
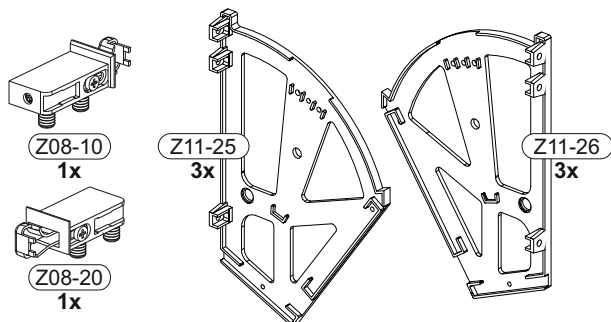
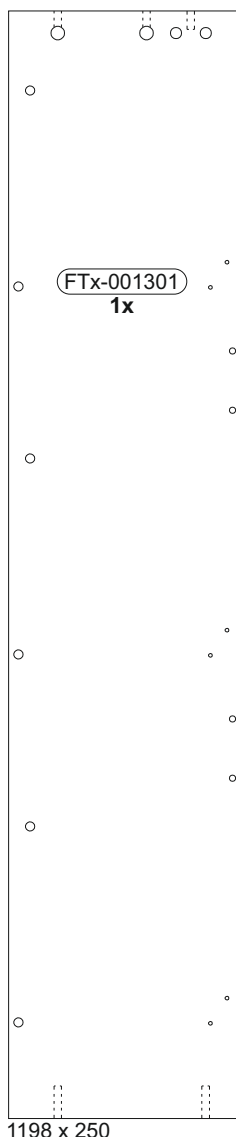

1

	B01-200		B01-80		B06-425sg		B05-178	
	24x	6,3x13	18x	3,5x13	3x	100x15x22	6x	

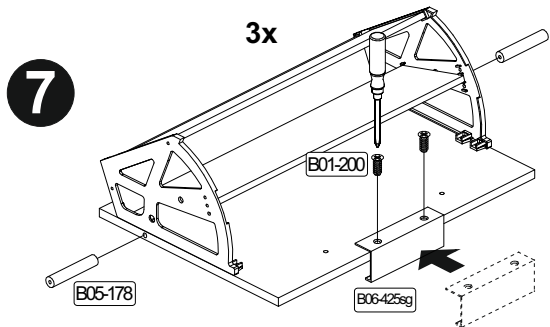
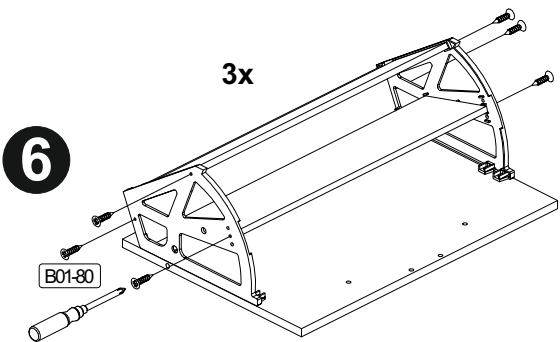
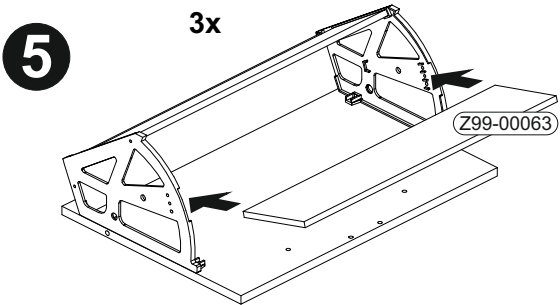
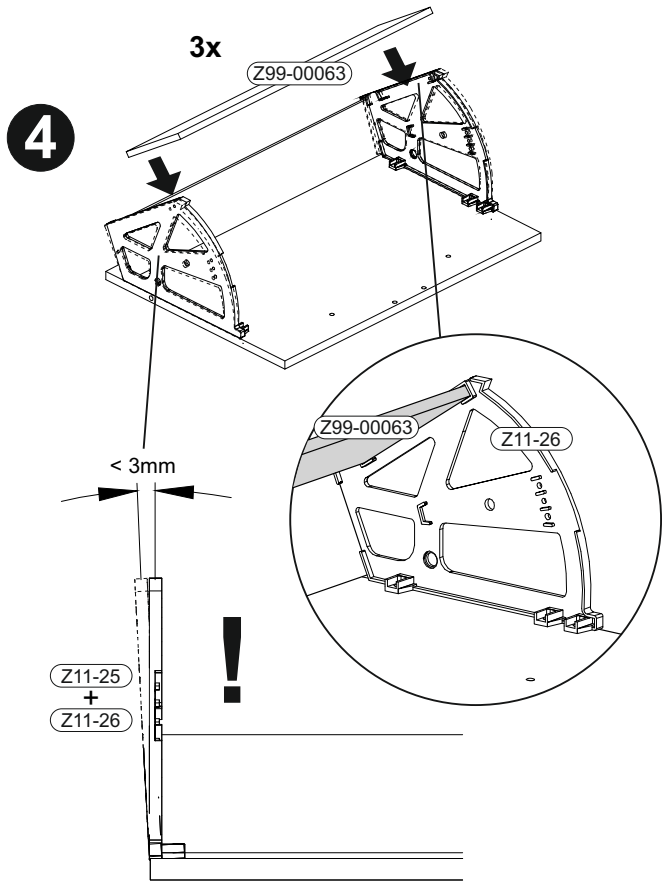
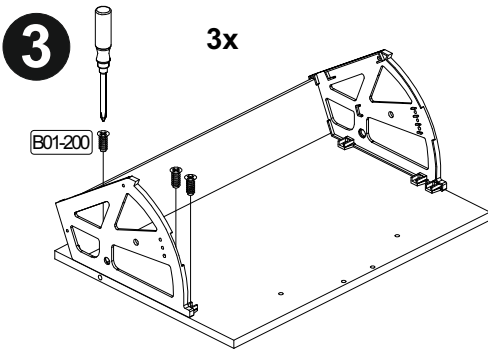
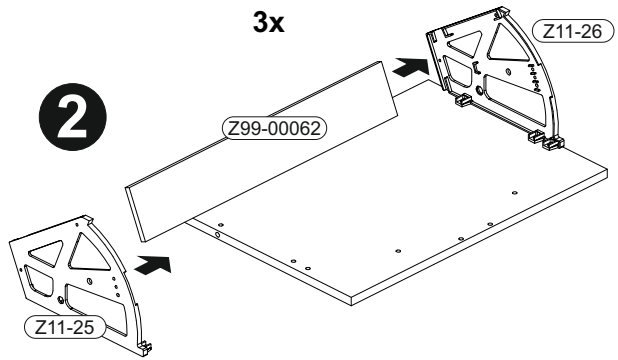
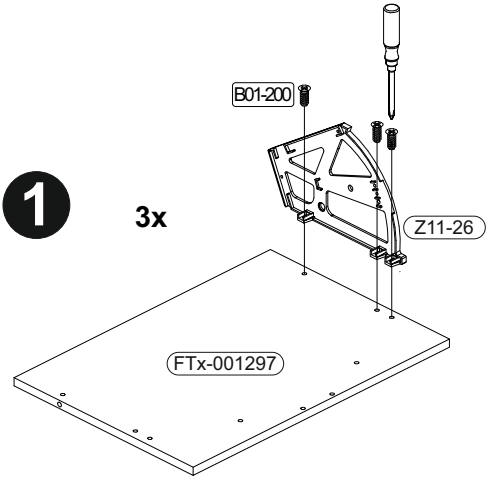

2

	B02-10		B02-20		B02-103		B05-121		B01-80	
	4x	ø15x12mm	8x		2x	8x30	6x		12x	3,5x13
					B03-81		B03-82		B05-174	
					6x		6x		6x	

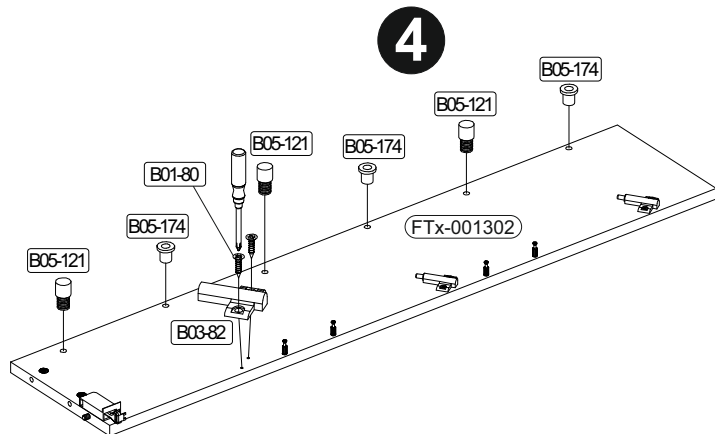
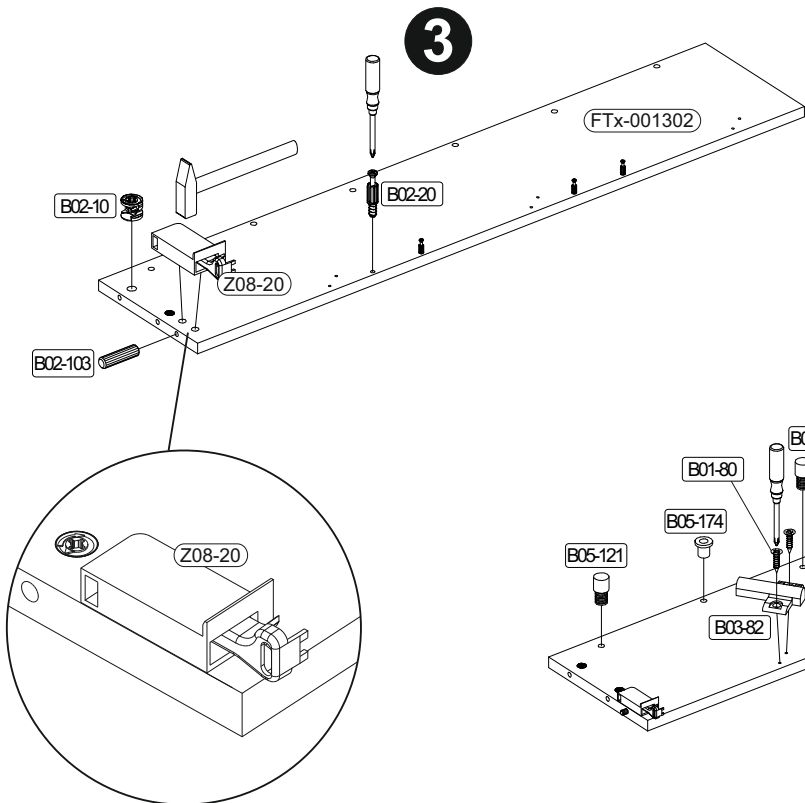
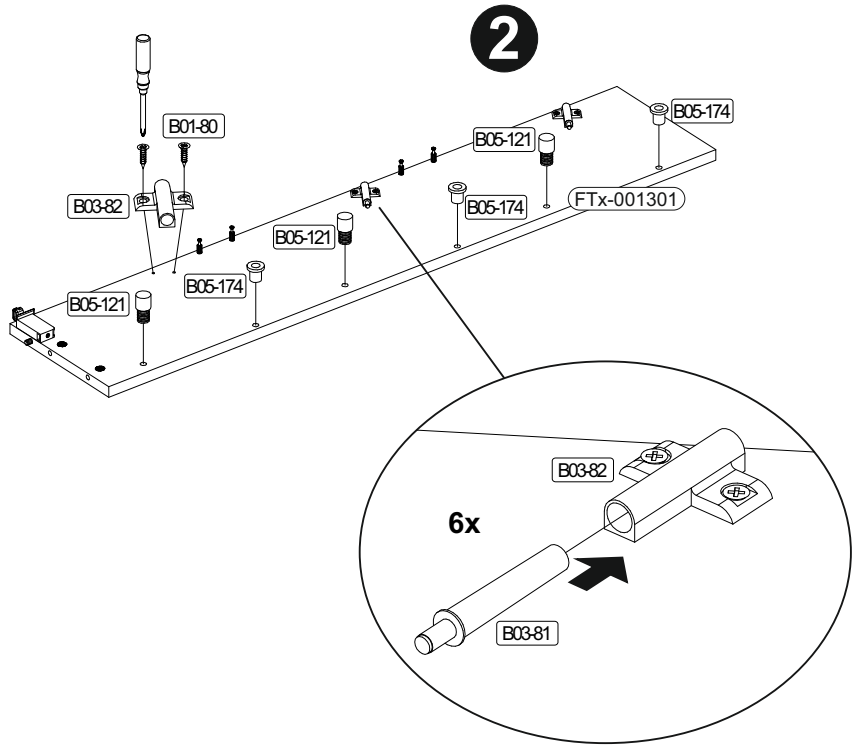
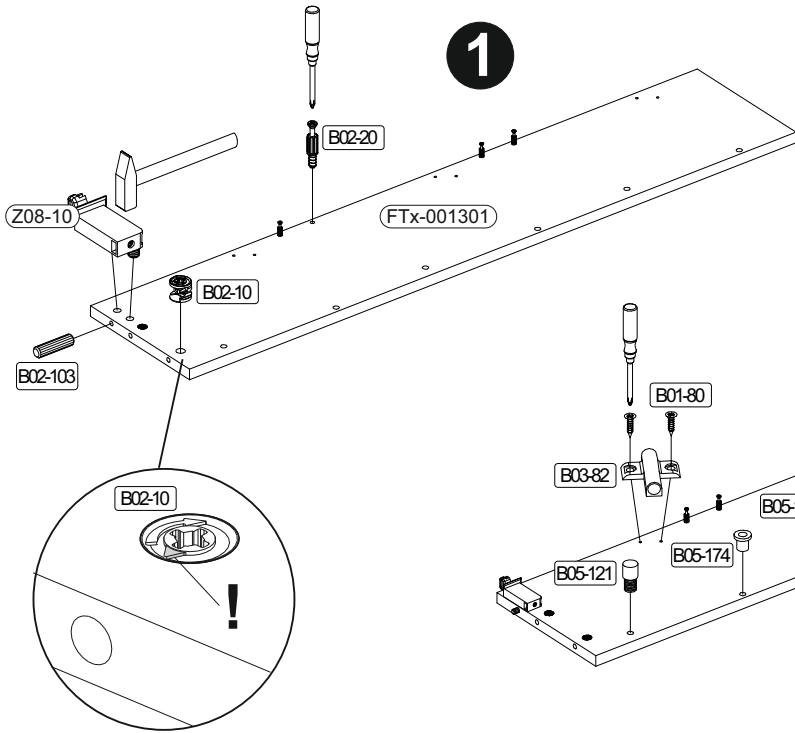

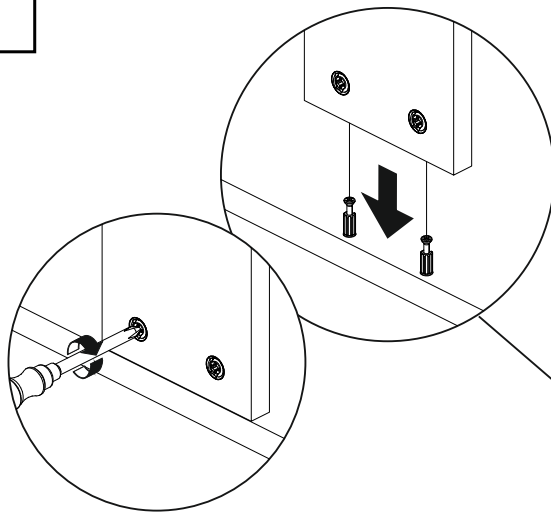
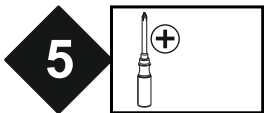
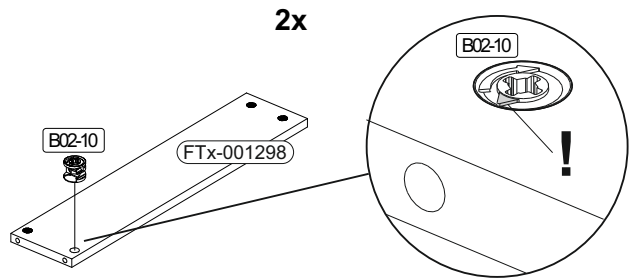
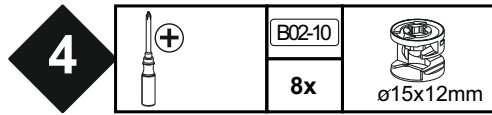
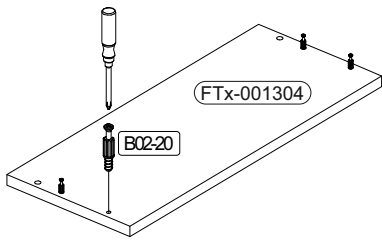
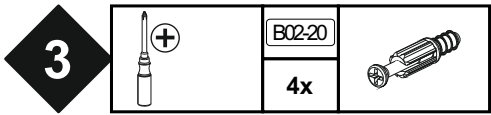

1

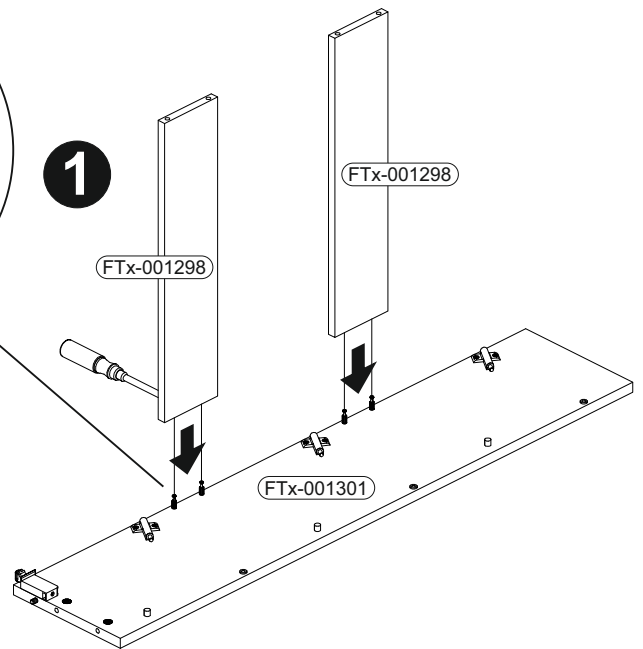

2

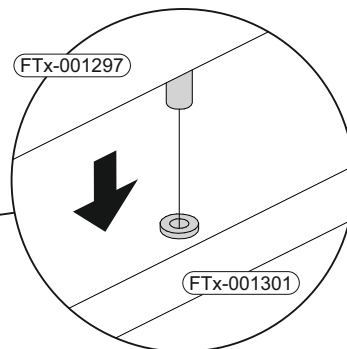
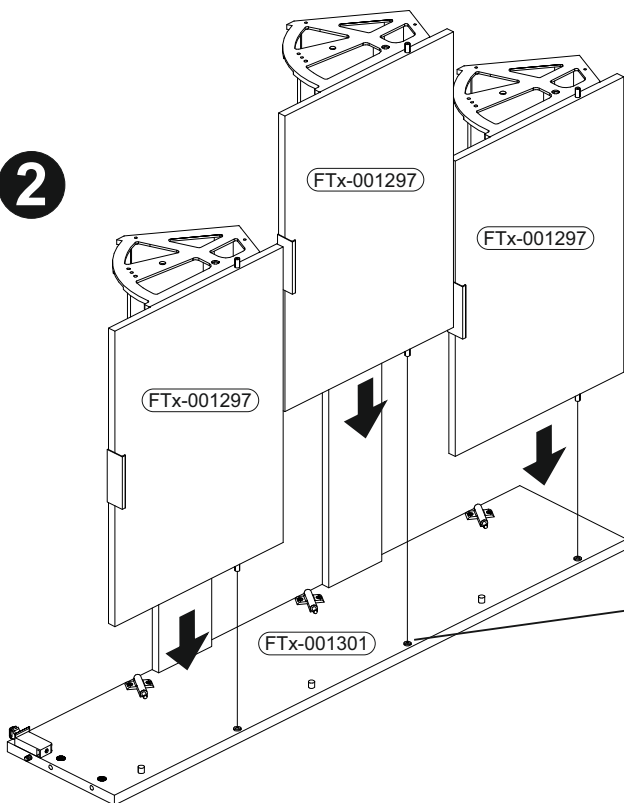

6

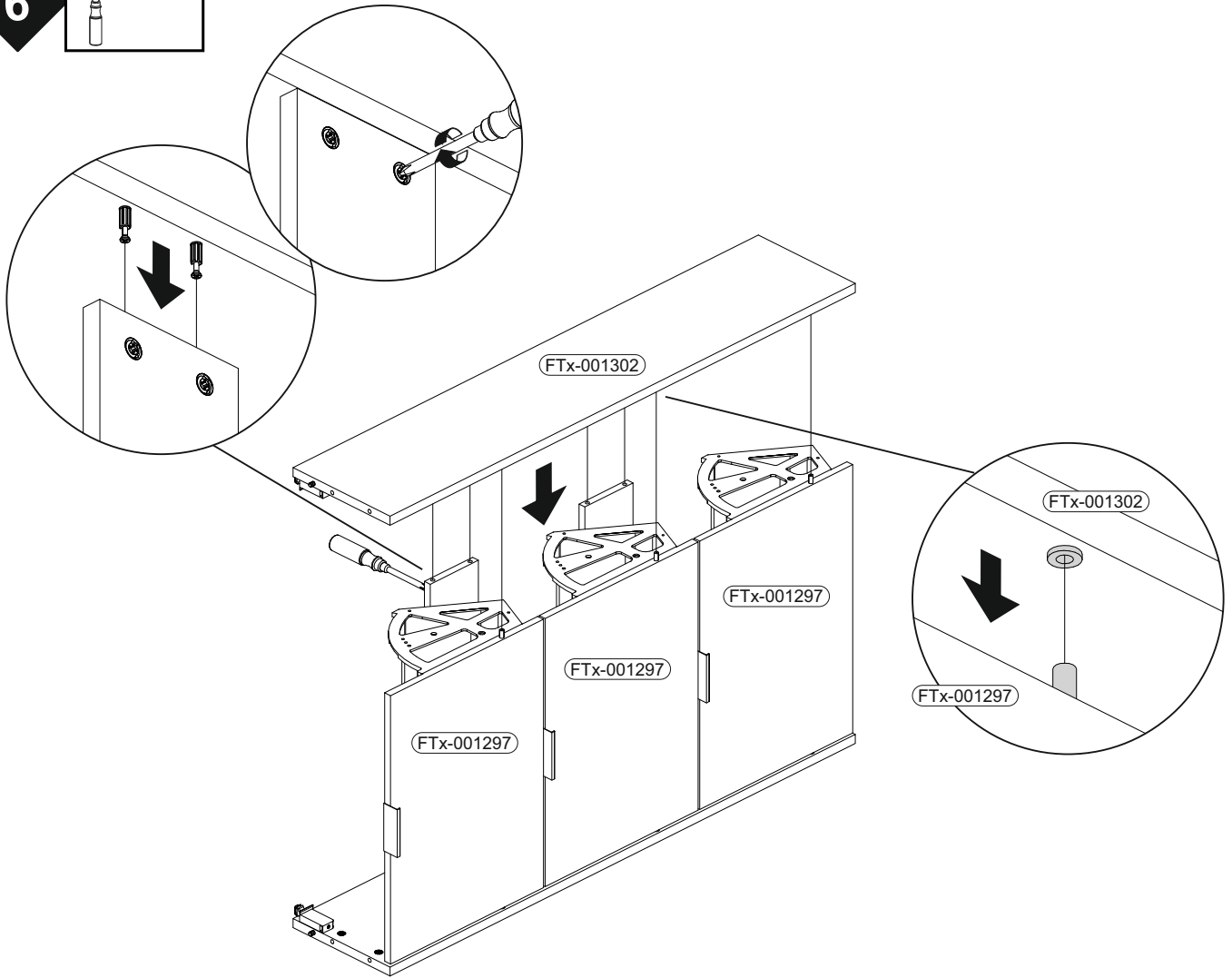
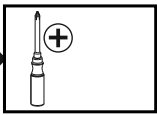

7

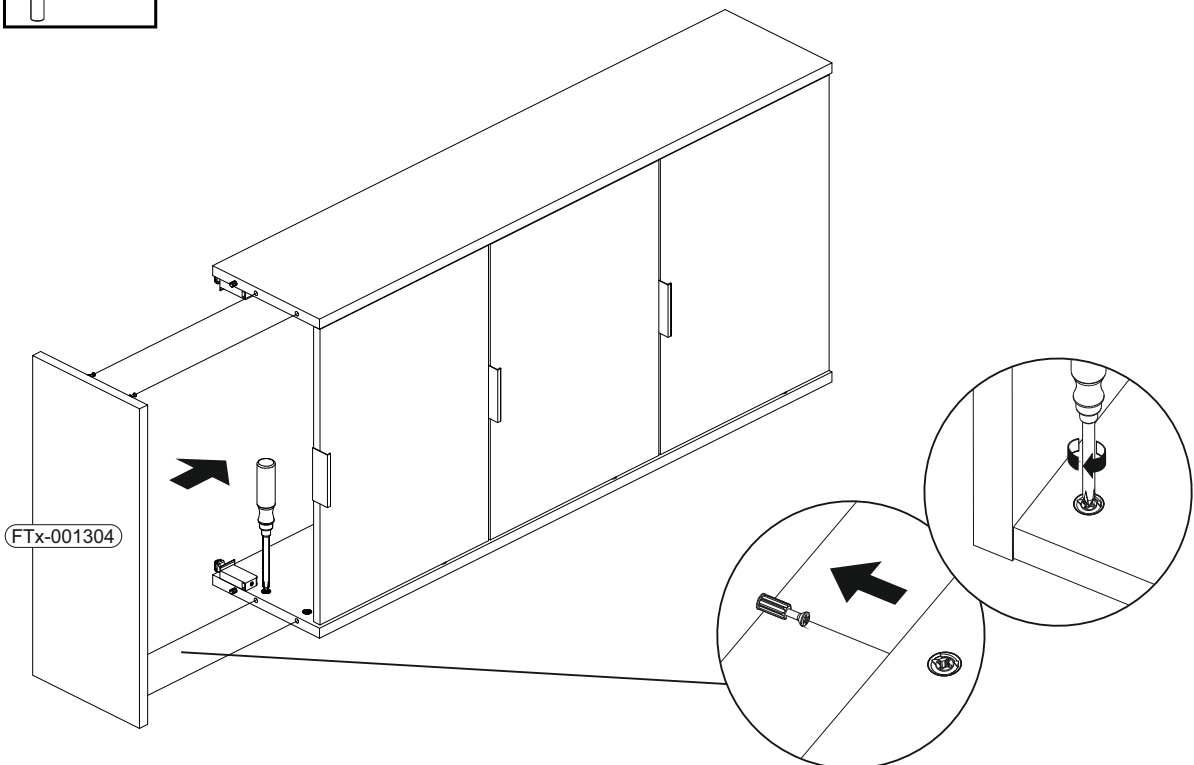
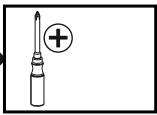



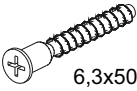

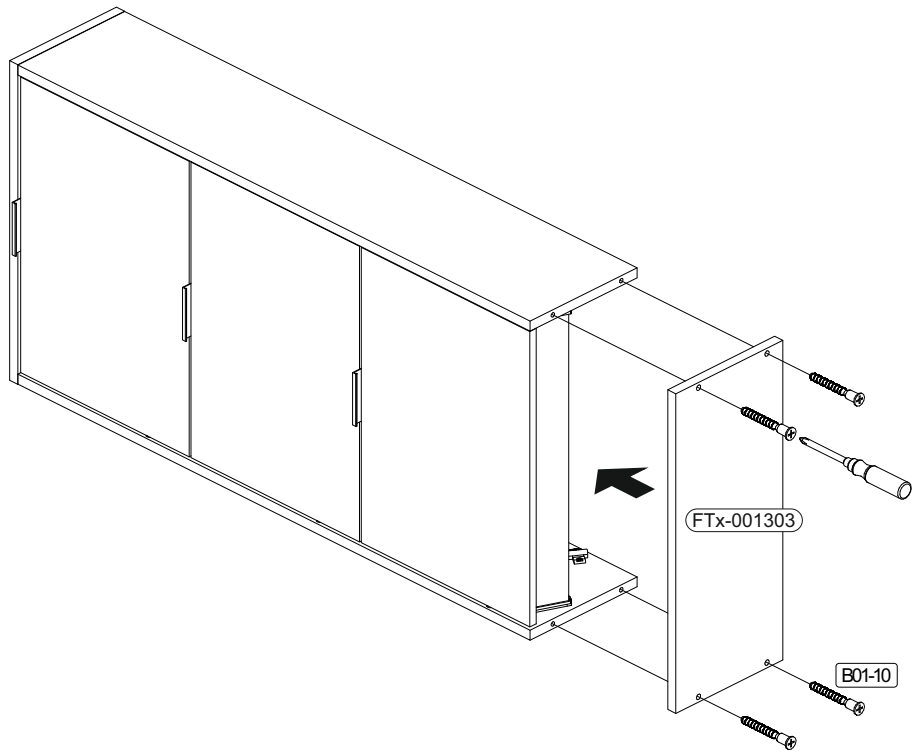
8

 +	B01-10	
	4x	

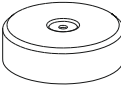

9

 +	B02-173			B01-123	
	4x			8x	

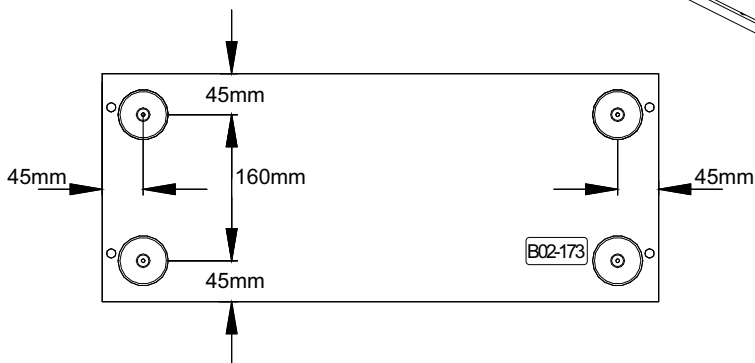
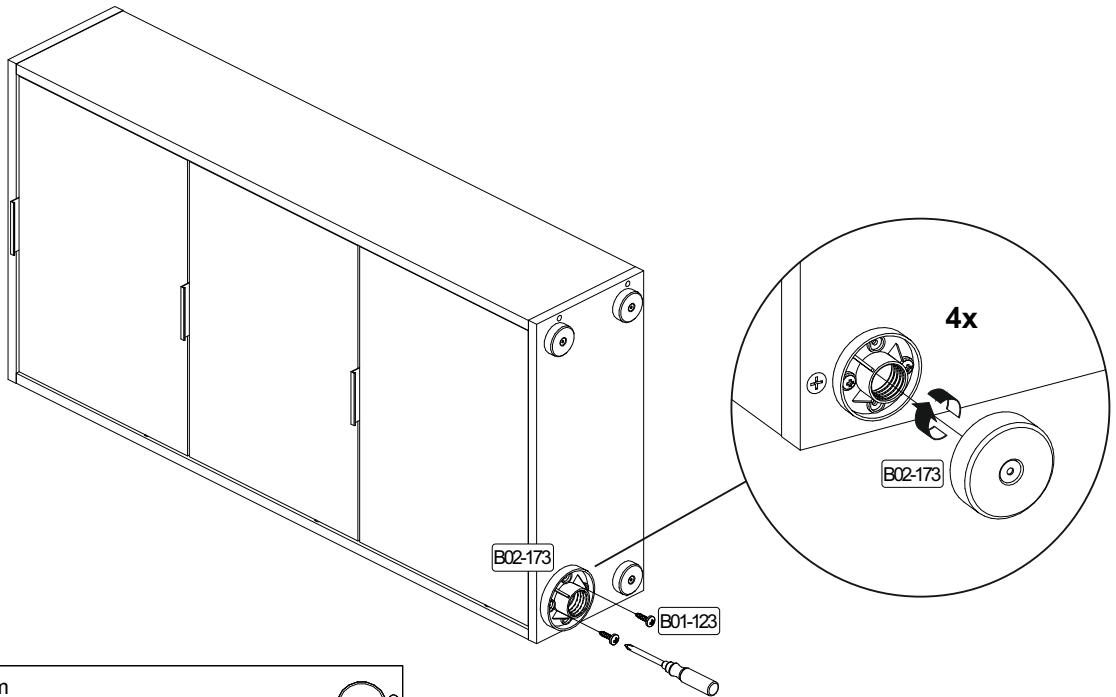

10

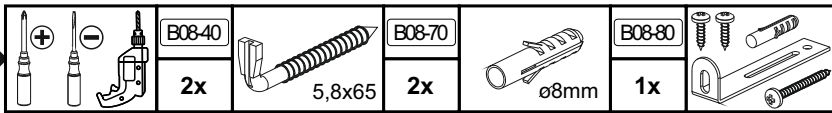

▶ SCAN ME

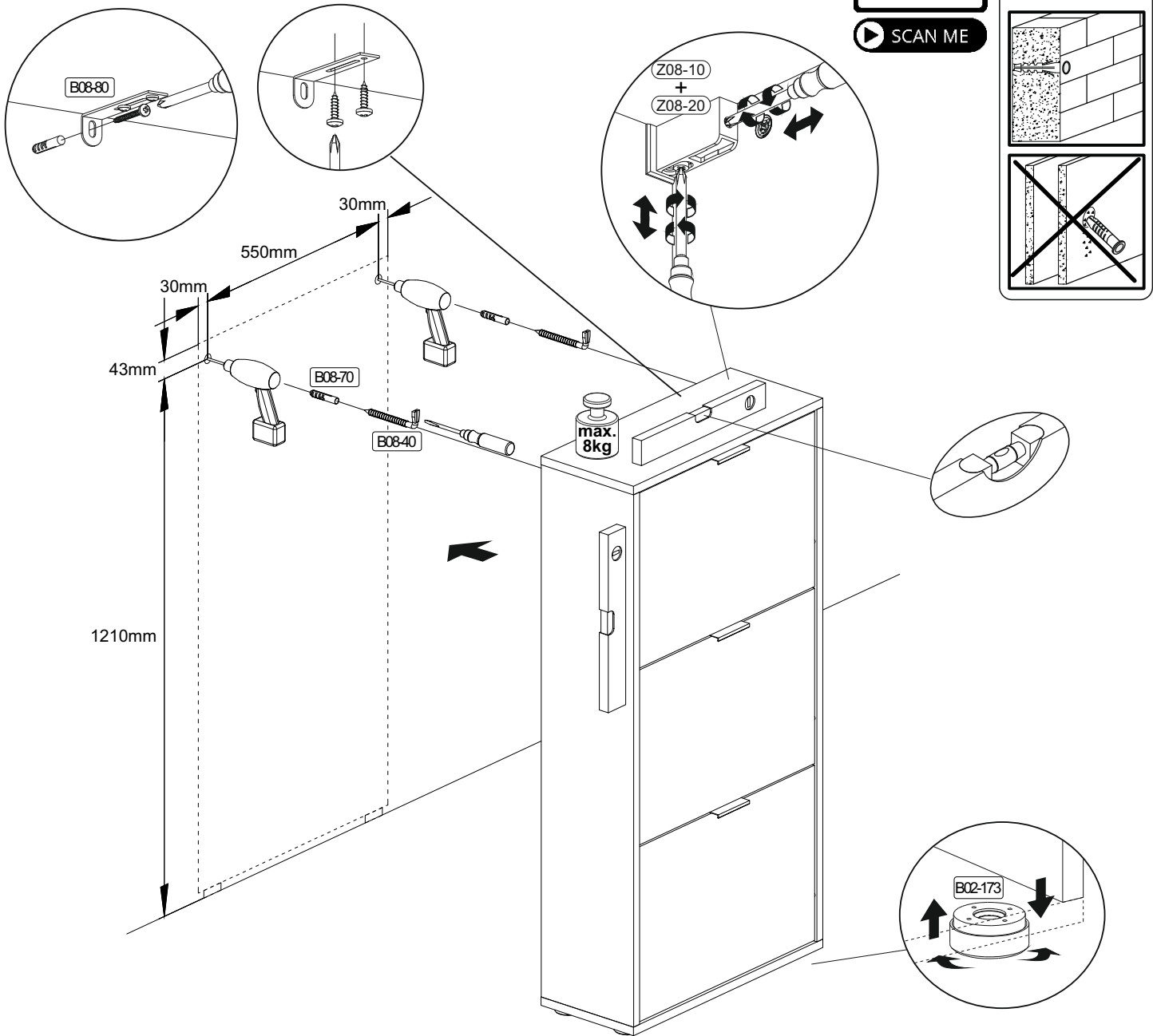
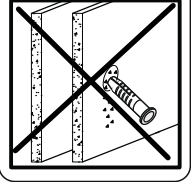
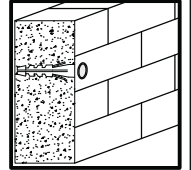

Achtung • Attention • Attenzione • Opgelet • Uwaga • Pozor • Figyelem • Atenție • Dikkat • Внимание	
(D)	Wandbefestigung dient als Kippschutz - unbedingt anbringen! Bei einigen Wandtypen kann ein Spezialdübel erforderlich sein!
(GB)	The wall fastening serves to prevent tipping - be absolutely sure to mount it! For certain wall types, a special wall plug may be necessary!
(FR)	La fixation murale sert de protection contre le basculement – à installer impérativement ! Pour certains types de murs il faut des chevilles spéciales !
(TR)	Duvardaki sabitleme, devrilmeye karşı bir emniyet tedbiridir ve mutlaka monte edilmelidir! Bazı duvar tiplerinde bunun için özel bir dübel gerekli olabilir!
(IT)	Il fissaggio alla parete serve da protezione anti-ribaltamento – attaccarla assolutamente! Per alcune strutture di parete può essere necessario un tassello speciale!
(NL)	Bevestiging aan de muur dient als kantelbescherming – zeker en vast bevestigen! Bij enkele muurtypes is een speciale plug misschien vereist!
(RU)	Обязательно установите крепление на стене во избежание опрокидывания! Для некоторых типов стен может потребоваться специальный дюбель!
(CZ)	Montáž na stěnu slouží jako ochrana proti převrhnutí – bezpodmínečně umístěte! U některých typů stěn může být zapotřebí speciální hmoždinka!
(HU)	A terméket a falhoz kel rögzíteni, különben az felborulhat! Egyes faltípusoknál speciális tiplit kell használni!
(RO)	Sistemul de fixare la perete servește ca protecție la răsturnare - de montat obligatoriu! Pentru unele tipuri de pereți este posibil să fie necesar un diblu special!
(SK)	Upevnenie na stenu slúži ako ochrana proti prevráteniu – bezpodmienečne použite! Pre niektoré druhy stien môže byť potrebná špeciálna hmoždinka!
(PL)	Mocowanie do ściany jest jednocześnie zabezpieczeniem przed przewróceniem – koniecznie zamontować! Do niektórych rodzajów ścian koniecznie zastosować specjalne kołki mocujące.